

PEMBROKE

Olive Downs Coking Coal Project

Additional Information to the
Environmental Impact Statement

Appendix G

**Additional Information on the
Road Transport Assessment**

RFI RESPONSE LETTER

Transport Engineering

REF: Q125681

DATE: 19 March 2019

Pembroke Olive Downs Pty Ltd

c/- Resource Strategies
24 McDougall Street
MILTON QLD 4064

OLIVE DOWNS COKING COAL PROJECT ROAD IMPACT ASSESSMENT – RFI RESPONSE LETTER

GTA Consultants has previously prepared a Road Impact Assessment (RIA) report (Revision C, dated 09/07/18), to support the Environmental Impact Statement (EIS) for the proposed Olive Downs Coking Coal Project (herein referred to as the Project). Following a review of the RIA, the Department of Transport and Main Roads (TMR) and Isaac Regional Council (IRC) have each submitted a Request for Further Information (RFI) on a number of items detailed within the RIA.

The following has been prepared to provide additional clarification on the assumptions adopted and assessment undertaken in the RIA in accordance with the requests from TMR and IRC. This includes:

- additional road link assessment (Section 2), including:
 - additional impact identification (Section 2.1);
 - additional link capacity assessment (Section 2.2);
- additional intersection analysis (Section 3); and
- additional pavement impact assessments (Section 4).

A description of the road network proposed to be used by Project traffic is also provided in Section 1 to clarify any potential confusion regarding the potential additional roads identified by the IRC which Pembroke does not propose to use for the Project (i.e. Iffley Connection Road, Carfax Road, Vermont Park Road and the southern extent of Annandale Road).

A summary of GTA's responses to relevant comments raised by TMR and IRC is provided at Attachment A, with further details provided in the following sections of this letter.

1. Project Route Assumptions

The RIA assumes all Project related traffic will use pre-determined routes to access the Project. These routes, as determined by the Proponent, are shown in Table 1.

Table 1: Project Route Assumptions

Origin / Destination	Coppabella	Moranbah	Dysart	Middlemount	Nebo	Mackay
Olive Downs South	<ul style="list-style-type: none"> Maloney Street Peak Downs Hwy Daunia Rd Annandale Rd 	<ul style="list-style-type: none"> Moranbah Access Road Peak Downs Hwy Daunia Rd Annandale Rd 	<ul style="list-style-type: none"> Golden Mile Rd Fitzroy Developmental Rd Peak Downs Hwy Daunia Rd Annandale Rd 	<ul style="list-style-type: none"> Dysart Middlemount Rd Fitzroy Developmental Rd Peak Downs Hwy Daunia Rd Annandale Rd 	<ul style="list-style-type: none"> Peak Downs Hwy Daunia Rd Annandale Rd 	<ul style="list-style-type: none"> Peak Downs Hwy Daunia Rd Annandale Rd
Willunga	<ul style="list-style-type: none"> Maloney Street Peak Downs Hwy Fitzroy Development Rd 	<ul style="list-style-type: none"> Moranbah Access Road Peak Downs Hwy Fitzroy Development Rd 	<ul style="list-style-type: none"> Golden Mile Rd Fitzroy Development Rd 	<ul style="list-style-type: none"> Dysart Middlemount Rd Fitzroy Development Rd 	<ul style="list-style-type: none"> Peak Downs Hwy Fitzroy Development Rd 	<ul style="list-style-type: none"> Peak Downs Hwy Fitzroy Development Rd

As indicated in Table 1, all Project related traffic will access the Olive Downs South domain from the northern section of Annandale Road via Peak Downs Highway and Daunia Road only. No construction-related or operational traffic is proposed to access the Project from the southern section of Annandale Road and adjoining roads.

As such, roads with the potential to have Project traffic generated impacts are restricted to the following:

1. Peak Downs Highway – Assessed in RIA (Revision C, dated 09/07/18).
2. Fitzroy Development Road – Assessed in RIA (Revision C, dated 09/07/18).
3. Daunia Road – Assessed in RIA (Revision C, dated 09/07/18).
4. Annandale Road – Assessed in RIA (Revision C, dated 09/07/18).
5. Maloney Street – Assessed in RIA (Revision C, dated 09/07/18).
6. Moranbah Access Road – Assessed in RIA (Revision C, dated 09/07/18).
7. Golden Mile Road – Assessed in this letter.
8. Dysart Middlemount Road – Assessed in this letter.

As raised by IRC in their RFI (dated 11/10/18), analysis of Golden Mile Road and Dysart Middlemount Road was not included in the original RIA Report, with more detailed analysis also requested for Moranbah Access Road. Golden Mile Road and Dysart Middlemount Road were excluded from the original RIA given the low traffic volumes currently on these roads. Nonetheless, additional assessment of these roads has been undertaken with the outcomes detailed in the following sections of this letter.

2. Additional Road Link Assessment

2.1 Impact Identification

Traffic surveys were undertaken at Golden Mile Road, Dysart Middlemount Road and Moranbah Access Road to determine the baseline conditions of these roads, with the survey results shown at Attachment B.

Table 2 summarises the comparison of baseline traffic to Project traffic to determine whether the 5% traffic impact threshold (in accordance with TMR’s Guide to Traffic Impact Assessment (GTIA) guideline) is exceeded for Golden Mile Road, Dysart Middlemount Road and Moranbah Access Road. This comparison has been undertaken for the critical design horizons of the Project as detailed below and shown in Figure 1:

- 2020: Maximum Olive Downs South domain workforce (combined construction and operational phase)
- 2028: Maximum combined Olive Downs South domain and Willunga domain workforce

Figure 1: Project Workforce Schedule

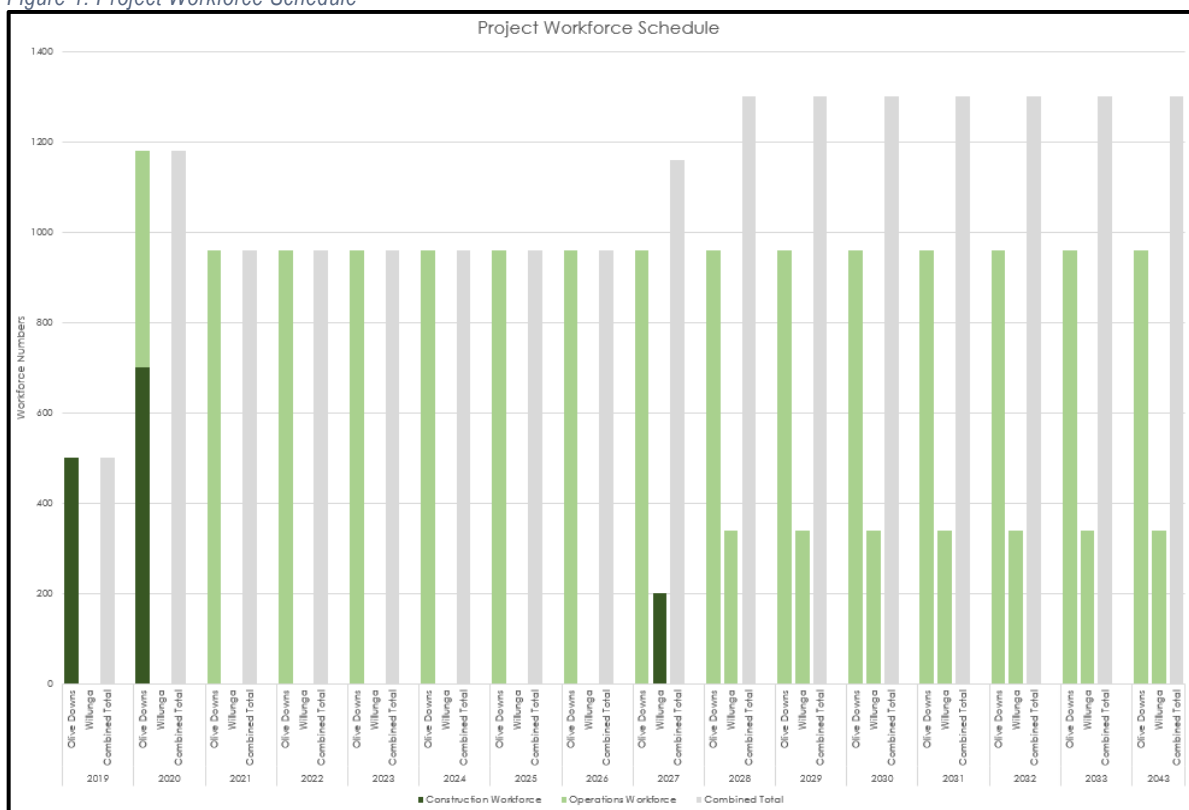

On the basis of the summary provide in Table 2, the impact of forecasted traffic for each critical design horizon is expected to exceed the 5% impact threshold for Golden Mile Road, Dysart Middlemount Road and Moranbah Access Road in both directions for the AM and PM peak periods. As previously discussed and confirmed in the traffic survey counts (Attachment B), Golden Mile Road, Dysart Middlemount Road and Moranbah Access Road all have minimal traffic currently using them resulting in an increase of over 5% with the addition of the Project traffic, despite minimal Project generated traffic using these roads.

Notwithstanding, a link capacity assessment for these affected roads is provided in section 2.2.

Table 2: Link Assessment – Impact Identification (Percentage Increase in Traffic Volume due to Project)

Road Name	Direction	2020		2028	
		AM Peak	PM Peak	AM Peak	PM Peak
Golden Mile Road	Eastbound (towards FDR)	>5%	>5%	>5%	>5%
Dysart Middlemount Road	Northbound (towards FDR)	>5%	>5%	>5%	>5%
Moranbah Access Road	Northbound (towards Moranbah)	>5%	>5%	>5%	>5%
Road Name	Direction	2020		2028	
		AM Peak	PM Peak	AM Peak	PM Peak
Golden Mile Road	Westbound (away from FDR)	>5%	>5%	>5%	>5%
Dysart Middlemount Road	Southbound (away from FDR)	>5%	>5%	>5%	>5%
Moranbah Access Road	Southbound (away from Moranbah)	>5%	>5%	>5%	>5%

2.2 Link Capacity Assessment

The theoretical capacity has been calculated in accordance with *Austrroads Guide to Traffic Management, Part 3* for two-lane, two-way roads. A summary of the anticipated LOS for each road link “with and “without” Project traffic is provided in Table 3 with detailed results including traffic volumes provided in Attachment C.

Table 3: Link Capacity Assessment Summary

AM Peak Period		2020		2028	
Road Name	Direction	Base	Base + Project	Base	Base + Project
Golden Mile Road	Eastbound (towards FDR)	A	A	A	A
	Westbound (away from FDR)	A	A	A	A
Dysart Middlemount Road	Northbound (towards FDR)	A	A	A	A
	Southbound (away from FDR)	A	A	A	A
Moranbah Access Road	Northbound (towards Moranbah)	A	A	A	B
	Southbound (away from Moranbah)	A	B	A	B
PM Peak Period		2020		2028	
Road Name	Direction	Base	Base + Project	Base	Base + Project
Golden Mile Road	Eastbound (towards FDR)	A	A	A	A
	Westbound (away from FDR)	A	A	A	A
Dysart Middlemount Road	Northbound (towards FDR)	A	A	A	A
	Southbound (away from FDR)	A	A	A	A
Moranbah Access Road	Northbound (towards Moranbah)	A	B	A	B
	Southbound (away from Moranbah)	A	B	A	B

Table 3 indicates that the level of service (LOS) of all assessed roads is expected to be within level “B” as a result of Project generated traffic and is above the acceptable LOS of “D”. Furthermore, the only road section to experience any reduction in its LOS (albeit to a small degree only) is Moranbah Access Road. Overall, no significant impacts are expected to occur as a result of Project generated traffic on these roads.

3. Additional Intersection Analysis

Intersection analysis using the SIDRA Intersection software has been undertaken for the Peak Downs Highway / Moranbah Access Road intersection to assess whether the existing intersection form is adequate to cater for the Project-generated traffic. Analysis was limited to this intersection only to address the specific request raised by IRC in their RFI (dated 11/10/18). As discussed in the previous section, a small reduction in the LOS (from level “A” to level “B”) is predicted to occur along the Moranbah Access Road link with the addition of Project traffic, and the analysis in this section therefore enables any potential impacts at its main point of access to/from the Peak Downs Highway to also be assessed for completeness.

A summary of the results from this analysis is shown in Table 4, with detailed results shown in Attachment D.

Table 4: Intersection Analysis - Peak Downs Highway / Moranbah Access Road

Scenario	Approach	Base Case				Base + Project Case			
		DOS	Ave Delay (sec)	95 th %tile Queue (m)	LOS	DOS	Ave Delay (sec)	95 th %tile Queue (m)	LOS
2020 AM	Moranbah Access Rd	0.30	6	10	A	0.52	8	30	A
	Peak Downs Hwy (S)	0.11	4	3	A	0.15	5	4	A
	Peak Downs Hwy (N)	0.06	6	3	-	0.22	6	10	-
2020 PM	Moranbah Access Rd	0.21	6	6	A	0.42	7	17	A
	Peak Downs Hwy (S)	0.25	6	9	A	0.34	7	13	A
	Peak Downs Hwy (N)	0.10	6	4	-	0.24	6	10	-
2028 AM	Moranbah Access Rd	0.35	6	13	A	0.59	8	40	A
	Peak Downs Hwy (S)	0.13	4	4	A	0.17	5	5	A
	Peak Downs Hwy (N)	0.07	6	3	-	0.23	6	11	-
2028 PM	Moranbah Access Rd	0.25	6	8	A	0.47	8	24	A
	Peak Downs Hwy (S)	0.30	6	11	A	0.40	8	17	A
	Peak Downs Hwy (N)	0.12	6	11	-	0.26	6	11	-

DOS – Degree of Saturation; LOS – Level of Service

Based on the results of the SIDRA intersection analysis shown in Table 4, the Peak Downs Highway / Moranbah Access Road intersection with its existing form and geometry is expected to continue to operate within capacity at the design year of 2028 with the addition of the Project-generated traffic.

Further to this, based on the potential increase in traffic along Golden Mile Road, the Golden Mile Road / Fitzroy Developmental Road intersection with its existing form and geometry is also expected to continue to operate within capacity at the design year of 2028 with the addition of the Project-generated traffic.

4. Pavement Impact Assessment

4.1 Revisions to Original Assessment

The Pavement Impact Assessment undertaken as part of the original RIA for the Peak Downs Highway and Fitzroy Developmental Road (FDR) has been revised in line with the comments issued by TMR (dated 04/10/18). The results of the revised assessment are shown in Attachment E.

As indicated in Attachment E, impacts of greater than 5% have been identified on various sections of the Peak Downs Highway and Fitzroy Developmental Road for a finite period during the construction phases of the Olive Downs South and Willunga domains only, with impacts at all other times (including during the operational phases of the Project) below the impact threshold. Sections which are expected to be impacted (using the TMR descriptions for these road links) are as follows:

- Peak Downs Highway:
 - West of Coppabella
 - East of Coppabella
 - East of Bee Creek
 - North of Braeside Road
 - Retreat Hotel Permanent Counter
 - WiM Site at Eton
 - West of Walkerston Township
 - East of Walkerston Cemetery
 - East of BSES
 - West of Bernborough Avenue
 - Bernborough Avenue - City Gates
- Fitzroy Developmental Road:
 - Valkyrie Permanent Counter

It is recommended that a Pavement Design specialist is engaged to determine the existing capacity of the pavement on affected links of the Peak Downs Highway and Fitzroy Developmental Road, in liaison with TMR. The results from this can be used to determine whether monetary contributions or other compensation is required to offset the pavement impacts generated by the Project during specific times at the locations identified above.

4.2 Additional Assessment

Moranbah Access Road

A Pavement Impact Assessment (PIA) was not undertaken for Moranbah Access Road as part of the original RIA given that heavy vehicle numbers to / from Moranbah as a result of the Project are expected to be minimal (approx. 16 movements / day maximum). However, to address the specific request raised by IRC in their RFI (dated 11/10/18), a PIA for Moranbah Access Road has been undertaken as part of this RFI response letter in accordance with TMR's GTIA

guidelines and Austroads Guide to Pavement Technology Part 2 document. The results of the assessment are provided in Attachment F.

As shown in Attachment F, impacts of larger than 5% have been identified along Moranbah Access Road for the life of the Project. It is assumed that the 5% impact threshold has likely been exceeded due to the low baseline heavy vehicle movements on Moranbah Access Road (similar to the outcomes of the road link impact assessment), since the Project only generates a maximum of ~16 vehicle movements per day (12 bus movements and 4 semi-trailer movements).

It is recommended that a Pavement Design specialist is contracted to determine the existing capacity of the pavement on Moranbah Access Road, in liaison with IRC, to determine whether monetary contributions or other compensation is required to offset the pavement impacts generated by the Project.

Other Roads

It is expected that a detailed Pavement design for Annandale Road will be prepared and submitted to IRC and TMR for consideration as part of the Annandale Road upgrade works package. The detailed road works designs and associated Road Use Management Plan for the construction works of this upgrade will be prepared and submitted to IRC and TMR prior to commencement of any construction works.

It should also be noted that Golden Mile Road and Dysart Middlemount Road have been excluded from the PIA, since the Project does not propose to use these roads for heavy vehicle movements during either construction or operation of the Project.

I trust the above assists. Naturally, should you have any questions or require any further information, please do not hesitate to contact me on (07) 3113 5000.

Yours sincerely

GTA CONSULTANTS



Steve Manton
Associate Director / RPEQ # 08352

encl.

Attachment A – Summary RFI Response Table

Attachment B – Traffic Survey Counts

Attachment C – Link Capacity Assessment Results

Attachment D – SIDRA Results – Moranbah Access Road / Peak Downs Highway

Attachment E – Revised PIA Results – Peak Downs Highway and FDR

Attachment F – Additional PIA Results – Moranbah Access Road

RFI RESPONSE LETTER

Transport Engineering



ATTACHMENT A

Summary RFI Response Table

Item Number	Agency	Comment Raised	GTA Response
1	Isaac Regional Council	"There is reference by the Proponent to upgrading the Daunia and Annandale Road to up to 8m in width where required. IRC requires the roads to be upgraded in accordance with Capricorn Municipal Development Guidelines and AustRoads Guidelines which will likely require the road to be upgraded to at least 8.4m in width, subject to the Pavement Impact Assessment and the Transport Impact Assessment. To that end, it is noted that supporting documentation for the Daunia and Annandale Road works has not been included in the EIS, including the Pavement Impact Assessment, Transport Impact Assessment and Road Use Management Plan."	Road works documentation such as Road Use Management Plans and designs of road upgrades and access intersections will be prepared and provided for consideration by TMR and Council during the detailed design phase of the project. Projex Partners has been engaged by the IRC to prepare the detailed designs for the first 21 km of road upgrades.
2	Isaac Regional Council	"IRC's discussions with the Proponent have focused on upgrade of all of Daunia Road and the northern portion of Annandale Road, terminating at the Olive Downs South Domain Access Road (which it understands is the section as highlighted in light and dark green in Figure 4-26). However, IRC is concerned by the statement "Parts of Annandale Road, from Daunia Road to the Olive Downs South domain mine access road, would be upgraded" rather than a commitment to an upgrade of the entire length of the road."	As per section 1.0 "Project Route Assumptions" of this letter, it is proposed that all Project traffic will access the Olive Downs Mine site from the northern end via Daunia Road and Annandale Road, eliminating the need to upgrade the southern section of Annandale Road past the Olive Downs South domain mine access road. GTA understands that this northern section will be upgraded where required in accordance with relevant design standards and guidelines, to provide a suitable road able to accommodate the additional traffic generated by the Project. Notwithstanding, Pembroke has agreed to conduct ongoing monitoring of the usage of the southern portion of Annandale Road and Iffley Connection Road, and if monitoring indicates that additional traffic



Item Number	Agency	Comment Raised	GTA Response
			is utilising this road, and impacts are being generated, Pembroke will determine whether upgrades are required in consultation with the IRC.
3	Isaac Regional Council	<p>"It is IRC's firm view that the Project will have a significant impact on the entirety of Annandale Road (ie. including south of the proposed Olive Downs South Domain Access Road), Iffley Connection Road and Vermont Park Road. Accordingly, IRC requires these roads to be included in the Infrastructure Agreement for the following reasons:</p> <ul style="list-style-type: none"> • The workforce proposed for Olive Downs South will be sourced in part from Dysart and Middlemount (19%), this is supported by the projected increase in traffic on the Fitzroy Developmental Road noted by the Proponent (65 Passenger Car Units/hr in 2020). • IRC notes the comments made by the Proponent that the main vehicle access route to Olive Downs South domain is proposed to be via Daunia Road, connecting to Annandale Road and the main vehicle access to the Willunga domain is proposed to be via Fitzroy Development Road. However, this does not preclude Project traffic from utilize the southern portion of Annandale Road (south of proposed Olive Downs South Domain Access Road) and the connecting Iffley Connection/Vermont Park Roads to access the Mine site. For example, it is anticipated that the following traffic will utilise this route: <ul style="list-style-type: none"> ○ Project traffic residing in Dysart/Middlemount or travelling DIDO from the Rockhampton area for the Olive Downs South domain phase of the Project; and ○ Project traffic travelling from Moranbah for the Willunga domain phase of the Project. <p>The alternative for this traffic is to travel an additional approximately 80km via the Fitzroy Development Road and Peak Downs Highway (and vice versa), which is unlikely.</p> • IRC has recently removed its traffic counters from the Iffley Connection Road, however it is noted that those traffic counters measured that 10 vehicles per day utilize the Iffley Connection Road. As with the northern portion of Daunia/Annandale Roads, it is noted that the Iffley Connection Road and the southern portion of Annandale Road are currently unsuited to the traffic volumes and pavement impact that the Project will generate." 	<p>As per section 1.0 "Project Route Assumptions" of this letter, it is proposed that all Project traffic will access the Olive Downs Mine site from the northern end via Daunia Road and Annandale Road only. Table 1 summarises the routes set for Project traffic use by the Proponent.</p> <p>Pembroke does not propose to utilise Annandale Road (south of the proposed Olive Downs South access road), Iffley Connection Road or Vermont Park Road for any Project related traffic.</p> <p>Although Iffley Connection Road and the southern portion of Annandale Road may provide shorter travel distances for employees travelling from the north to the Willunga domain, it should be noted that operations at Willunga would not commence until 2028 and, as such, for the first nine years of the Project, there is expected to be minimal traffic travelling to the Willunga domain.</p> <p>Pembroke has been in discussions with the Isaac Regional Council (IRC) regarding the potential use of these roads and has agreed to conduct ongoing monitoring of the usage of the southern portion of Annandale Road and Iffley Connection Road, to determine whether there is an increase in traffic movement associated with the Project. If monitoring indicates that additional traffic is utilising these sections of road, and impacts are being generated, Pembroke would determine whether upgrades are required in consultation with the IRC.</p>

Item Number	Agency	Comment Raised	GTA Response
4	Isaac Regional Council	<p>"Taking into consideration the abovementioned comments, IRC expects that the following intersections will need to be reviewed by the Proponent and DTMR and upgraded accordingly keeping the traffic speed maintained in the respective intersections:</p> <ul style="list-style-type: none"> • Carfax/Golden Mile Road; • Carfax/Fitzroy Developmental Road; • Fitzroy Developmental/Iffley Connection Road; and • Iffley Connection/Annandale Road." 	<p>In line with the above-mentioned comments and the selected Project traffic routes outlined in Table 1 of this report, only the following Local Road intersections have been reviewed:</p> <ul style="list-style-type: none"> • Fitzroy Developmental Road / Golden Mile Road • Fitzroy Developmental Road / Dysart Middlemount Road
5	Isaac Regional Council	<p>"Within Appendix J, it is identified "the majority if not all of the traffic utilising Annandale Road would be Project-related traffic. As such, a basic left turn and right turn treatment from Annandale Road to the site access is expected to be sufficient." IRC is concerned that this may result in safety concerns and extended queuing of southbound traffic resulting from:</p> <ul style="list-style-type: none"> • Project traffic residing in Dysart/Middlemount or travelling DIDO from the Rockhampton area for the Olive Downs South domain phase of the Project; and • Project traffic travelling from Moranbah for the Willunga domain phase of the Project • General through traffic <p>Accordingly, IRC requires that further traffic modelling needs to be undertaken by the Proponent with the results of same determining the level of upgrade of the intersection/intersection treatment, pursuant to AustRoads standards."</p>	<p>As per section 1.0 "Project Route Assumptions" of this letter, it is proposed that all Project traffic will access the Olive Downs Mine site from the northern end of Daunia Road / Annandale Road, eliminating the following safety concerns raised by IRC:</p> <p><i>"extended queuing of southbound traffic resulting from:</i></p> <ul style="list-style-type: none"> • <i>Project traffic residing in Dysart/Middlemount or travelling DIDO from the Rockhampton area for the Olive Downs South domain phase of the Project; and</i> • <i>Project traffic travelling from Moranbah for the Willunga domain phase of the Project"</i> <p>As mentioned in section 8.2.1 of Appendix J, existing traffic on Annandale Road (northbound and southbound) is minimal and therefore it is expected that no safety concerns will arise from general southbound through traffic on Annandale Road proximate to the proposed site access.</p> <p>On the basis of the above and the turn warrant assessment (in accordance with Austroads Guidelines) undertaken in section 8.2 of Appendix J, a basic left turn and right turn treatment from Annandale Road to the site access is expected to be sufficient.</p>
6	Isaac Regional Council	<p>"It is identified that 25% of the workforce is to be transported by bus, however there is no identification of suitable set down areas within the identified accommodation centres."</p>	<p>Pembroke has confirmed that the proposed accommodation centres in Moranbah and Coppabella have suitable set down areas for buses to facilitate the travel of personnel residing in these centres to and from project sites.</p>

Item Number	Agency	Comment Raised	GTA Response
7	Isaac Regional Council	"Fleeting reference is made to Saraji Road, Golden Mile Road and Carfax Road; however no detail is provided as to the project related use and by omission it could be implied that the Proponent does not consider that the Project will have no impact on those roads. It is not accepted by IRC that the Project will have no impact on these roads and IRC requires that Traffic Impact Assessments should be carried out in relation to these roads."	<p>Section 1.0 "Project Route Assumptions" of this letter details the travel routes set by the Proponent for Project related traffic use. As indicated within this section, Project related traffic will not be utilising Saraji Road and Carfax Road to access the mine sites. As such, these roads have been excluded from the Traffic Impact Assessment.</p> <p>A Traffic Impact Assessment of Golden Mile Road has been undertaken, with the outcomes detailed in section 2.0 of this letter.</p>
8	Isaac Regional Council	"As noted in comments regarding the SIA, whilst it is noted that the Proponent has indicated most operational traffic will access the mine site via bus, IRC requires that a traffic and pavement impact assessment should be carried out with respect to Moranbah Access Road to properly quantify Project impacts on these roads. Furthermore, while the intersection modelling of the Peak Downs Highway/Moranbah Access Road provides intersection requirements across the Peak Downs Highway, it is unclear as to the impact that the project traffic may have on Moranbah Access Road. Without further evidence provided by the Proponent, IRC does not accept the Proponent's view that the existing configuration of the Moranbah Access Road approach/exit geometrics (North & South Bound lanes) will completely provide for safe travel as a result of the expected increase due to project related traffic. It is therefore considered that these geometrics should be reviewed based on the results from the traffic impact assessment."	<p>Additional assessment of Moranbah Access Road and the Peak Downs Highway / Moranbah Access Road intersection has been undertaken, with details and outcomes provided in the following sections of this letter:</p> <ul style="list-style-type: none"> • Section 2.0 Road Link Assessment; • Section 3.0 Additional Intersection Analysis; and • Section 4.0 Pavement Impact Assessment.

Item Number	Agency	Comment Raised			GTA Response
9	Department of Transport and Main Roads	Sheet Name	Submitted	Comment	The original Pavement Impact Assessment has been revised in line with the comments raised by TMR. Details and outcomes of the revised analysis are provided in section 4.0 Pavement Impact Assessment of this letter.
		Background Axle Group	The following are typical formulae that have been used to calculate the number of axle group types for each year separated into gazetted direction and against: =('Axle Group Notes'!\$F\$12''AADT by HV Type Gazetted'!\$Q\$6 =('Axle Group Notes'!\$F\$12''AADT by HV Type Against'!\$Q\$6	There are numerous instances of the "against" formula used in the Gazetted columns and the "gazetted" formula used in the Against columns. This should be corrected.	
		Background ESA Background SAR5 Project ESA Project SAR5	These Sheets calculate the total ESA (SAR4) and SAR5 values for each heavy vehicle type and axle configuration, and the total SARs for each road link and project year. The formulae used to calculate the total ESA and SAR values generally take the form of – ((Max Load x No of Axles)/Base Load)^4 for ESA (SAR4) and ((Max Load x No of Axles)/Base Load)^5 for SAR5. I think this is incorrect. Example: =('Axle Group Notes'!\$E\$28''Background Axle Group'!E4)/Axle Group Notes'!\$E\$24)^4	To calculate ESA and SAR values: (Max Load/Base Load)^4 for ESA (SAR4). Total ESA (SAR4) would then be: ((Max Load/Base Load)^4) x No of Axles Similarly for SAR5: ((Max Load/Base Load)^5) x No of Axles The formulae on the four Sheets should be amended and the new results discussed in your report. It appears that this may have a significant impact on the results. Example: =('Axle Group Notes'!E\$28/Axle Group Notes'!E\$24)^4''Background Axle Group'!E4	
		SAR5 % Change	I'm not sure why SAR5 values have been compared. Table 6.4 on page 15 of the GTIA is not specific.	Historically we used ESA (SAR4) numbers to determine the >5% impact. It may not make a difference to compare SAR4s or SAR5s as the comparison should produce the same result.	

RFI RESPONSE LETTER

Transport Engineering

ATTACHMENT B

Traffic Survey Counts

AUSTRAFFIC VIDEO INTERSECTION COUNT



Site No.: 1 Weather: Fine

Location: Golden Mine Road/Fitzroy Developmental Road

Day/Date: 14 November 2018

Summary: AM Peak : Hour ending - 7:45 AM
 PM Peak : Hour ending - 4:45 PM

Hour Ending: 7:45 AM

Classification: Total Vehicles

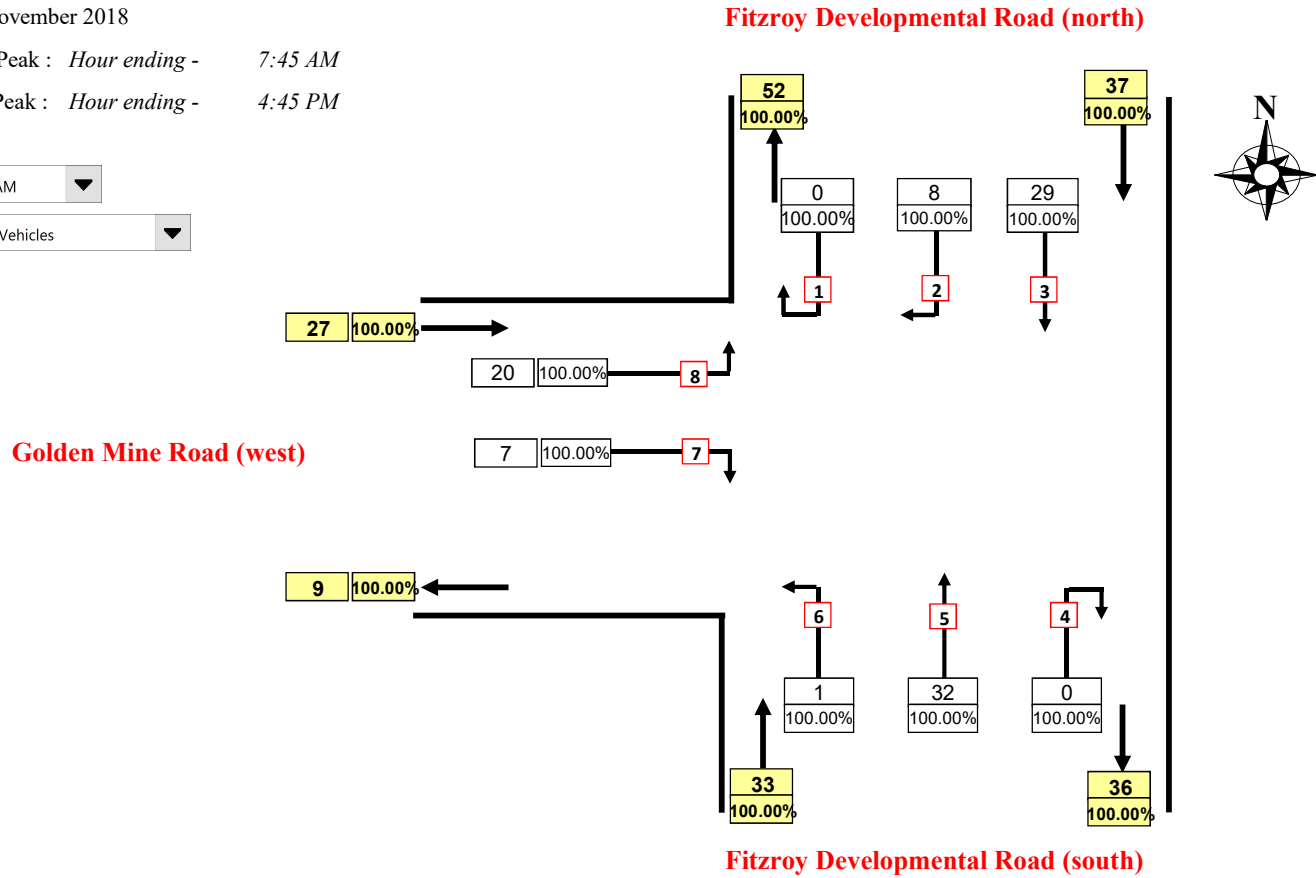

Note: 3.28% = proportion of selected vehicle classification as a percentage of total vehicles

AUSTRAFFIC VIDEO INTERSECTION COUNT



Site No.: 1 Weather: Fine

Location: Golden Mine Road/Fitzroy Developmental Road

Day/Date: 14 November 2018

Summary: AM Peak : Hour ending - 7:45 AM
 PM Peak : Hour ending - 4:45 PM

Hour Ending: 4:45 PM

Classification: Total Vehicles

Fitzroy Developmental Road (north)

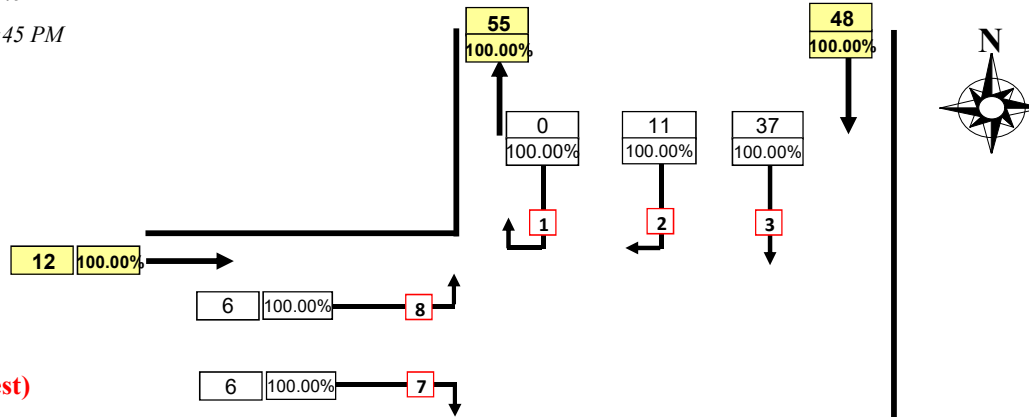

Fitzroy Developmental Road (south)

Note: 3.28% = proportion of selected vehicle classification as a percentage of total vehicles

AUSTRAFFIC VIDEO INTERSECTION COUNT



Site No.: 2 Weather: Fine

Location: Dysart Middlemount Road/Fitzroy Development Road

Day/Date: 14 November 2018

Summary: AM Peak : Hour ending - 7:45 AM

PM Peak : Hour ending - 4:15 PM

Hour Ending: 7:45 AM

Classification: Total Vehicles

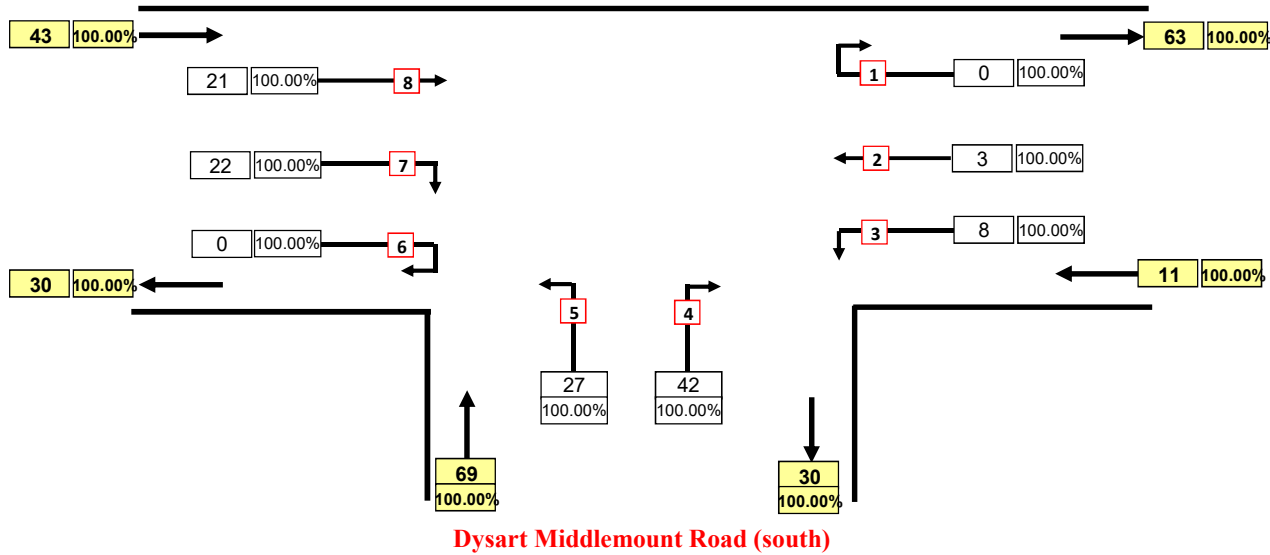

Note: 3.28% = proportion of selected vehicle classification as a percentage of total vehicles

AUSTRAFFIC VIDEO INTERSECTION COUNT



Site No.: 2 Weather: Fine

Location: Dysart Middlemount Road/Fitzroy Development Road

Day/Date: 14 November 2018

Summary: AM Peak : Hour ending - 7:45 AM

PM Peak : Hour ending - 4:15 PM

Hour Ending: 4:15 PM

Classification: Total Vehicles

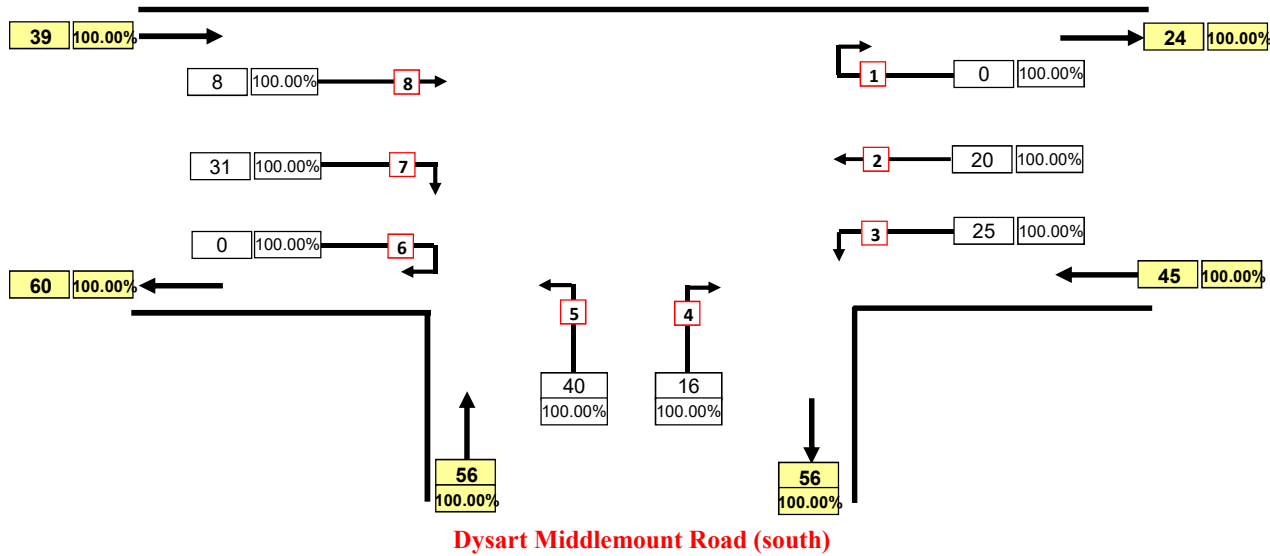

Fitzroy Development Road (west)

Fitzroy Development Road (east)

Dysart Middlemount Road (south)

Note: 3.28% = proportion of selected vehicle classification as a percentage of total vehicles

AUSTRAFFIC VIDEO INTERSECTION COUNT



Site No.: 3 Weather: Fine

Location: Peak Downs Highway/Moranbah Access, Moranbah

Day/Date: 10 January 2018

Summary: 12 Hour Volumes : 6:00 AM to 6:00 PM

AM Peak : Hour ending - 7:00 AM

PM Peak : Hour ending - 6:00 PM

Hour Ending: 7:00 AM

Classification: Total Vehicles

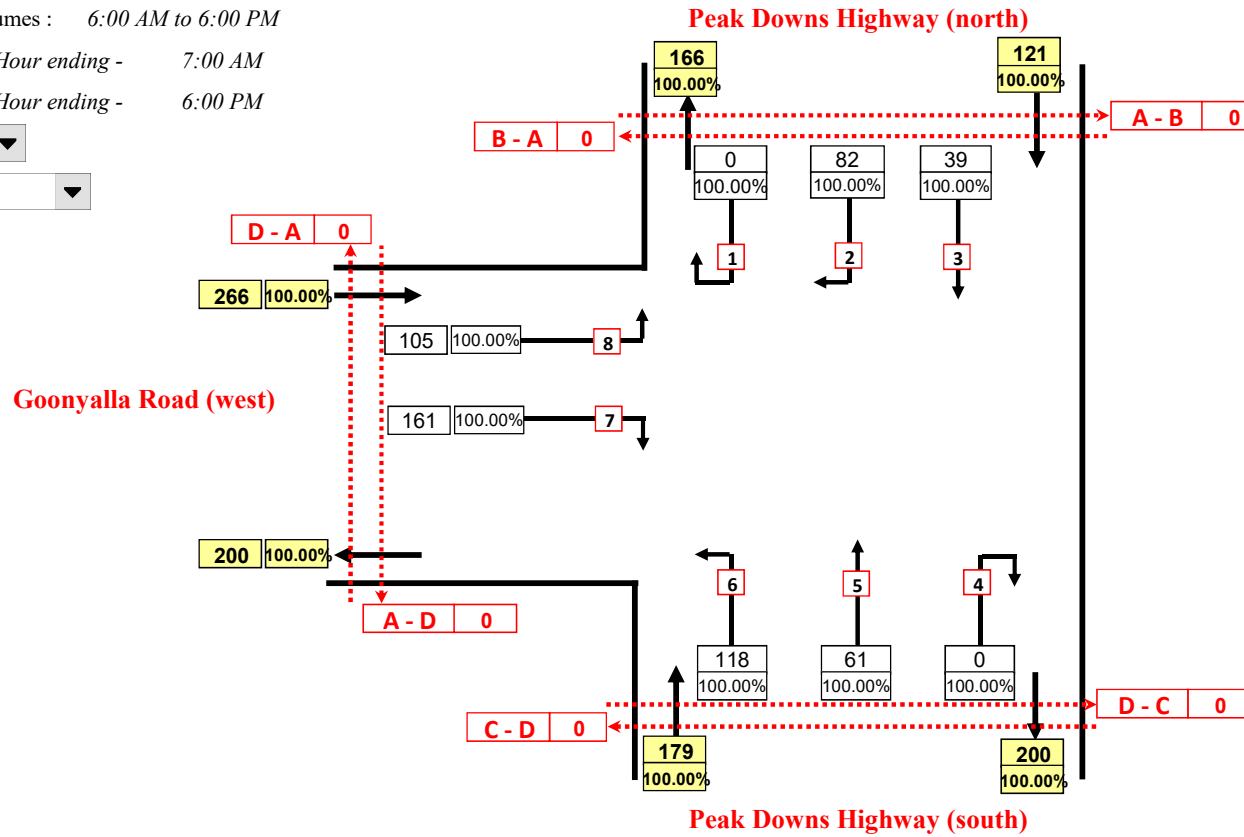

Note: 3.28% = proportion of selected vehicle classification as a percentage of total vehicles

AUSTRAFFIC VIDEO INTERSECTION COUNT



Site No.: 3 Weather: Fine

Location: Peak Downs Highway/Moranbah Access, Moranbah

Day/Date: 10 January 2018

Summary: 12 Hour Volumes : 6:00 AM to 6:00 PM

AM Peak : Hour ending - 7:00 AM

PM Peak : Hour ending - 6:00 PM

Hour Ending: 6:00 PM

Classification: Total Vehicles

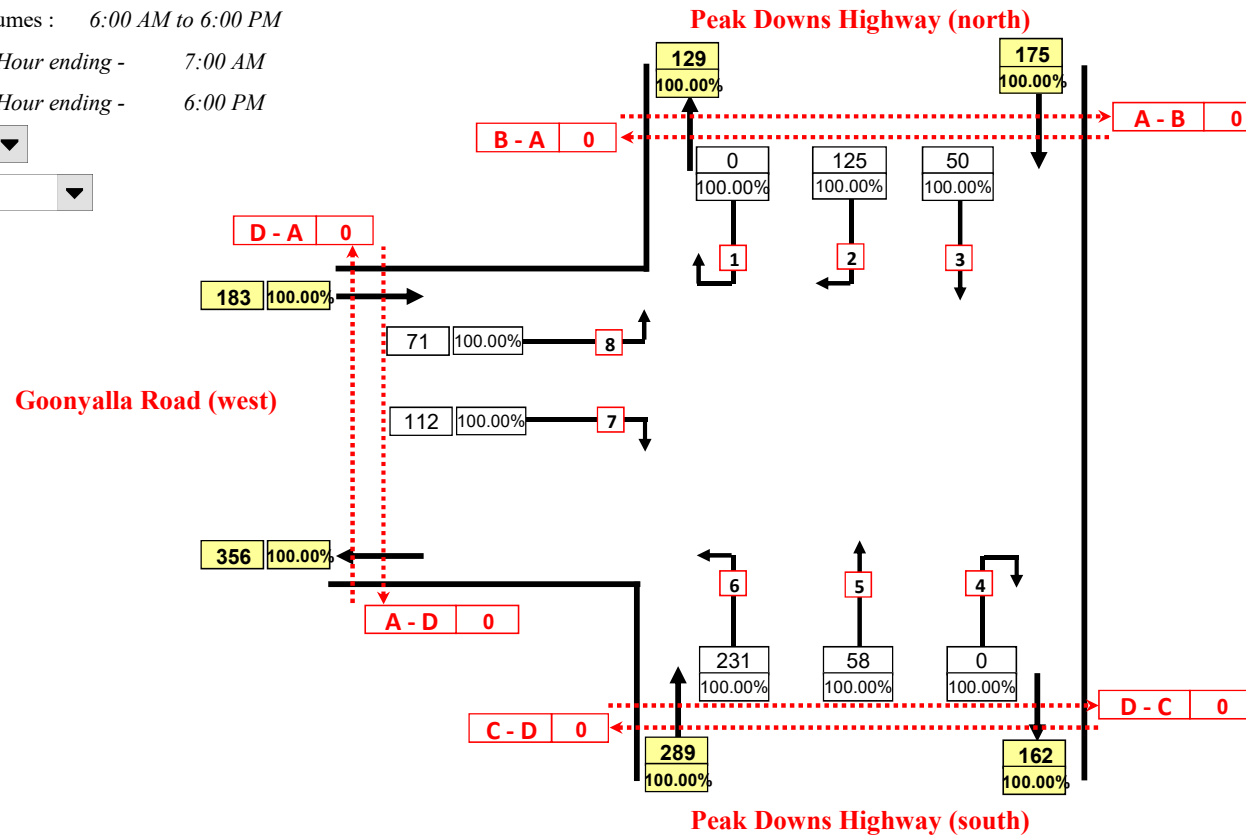

Note: 3.28% = proportion of selected vehicle classification as a percentage of total vehicles

RFI RESPONSE LETTER

Transport Engineering

ATTACHMENT C

Link Capacity Assessment Results (PCU/hr = Passenger Car Units per Hour, LOS = Level of Service)

AM Peak Period		2020				2028			
Road Name	Direction	Base		Base + Project		Base		Base + Project	
		Total PCU/hr	LOS	Total PCU/hr	LOS	Total PCU/hr	LOS	Total PCU/hr	LOS
Golden Mile Road	Eastbound (towards FDR)	55	A	167	A	70	A	192	A
	Westbound (away from FDR)	14	A	126	A	9	A	131	A
Dysart Middlemount Road	Northbound (towards FDR)	98	A	163	A	122	A	196	A
	Southbound (away from FDR)	53	A	118	A	49	A	123	A
Moranbah Access Road	Northbound (towards Moranbah)	213	A	441	A	261	A	514	B
	Southbound (away from Moranbah)	324	A	498	B	375	A	562	B
PM Peak Period		2020				2028			
Road Name	Direction	Base		Base + Project		Base		Base + Project	
		Total PCU/hr	LOS	Total PCU/hr	LOS	Total PCU/hr	LOS	Total PCU/hr	LOS
Golden Mile Road	Eastbound (towards FDR)	55	A	167	A	59	A	181	A
	Westbound (away from FDR)	35	A	147	A	39	A	161	A
Dysart Middlemount Road	Northbound (towards FDR)	84	A	149	A	75	A	149	A
	Southbound (away from FDR)	88	A	153	A	97	A	170	A
Moranbah Access Road	Northbound (towards Moranbah)	381	A	610	B	446	A	699	B
	Southbound (away from Moranbah)	269	A	498	B	309	A	562	B

RFI RESPONSE LETTER

Transport Engineering

ATTACHMENT D

SIDRA Results – Moranbah Access Road / Peak Downs Highway

NETWORK LAYOUT

Network: N101 [2020 AM - Base Case]

New Network
 Network Category: (None)

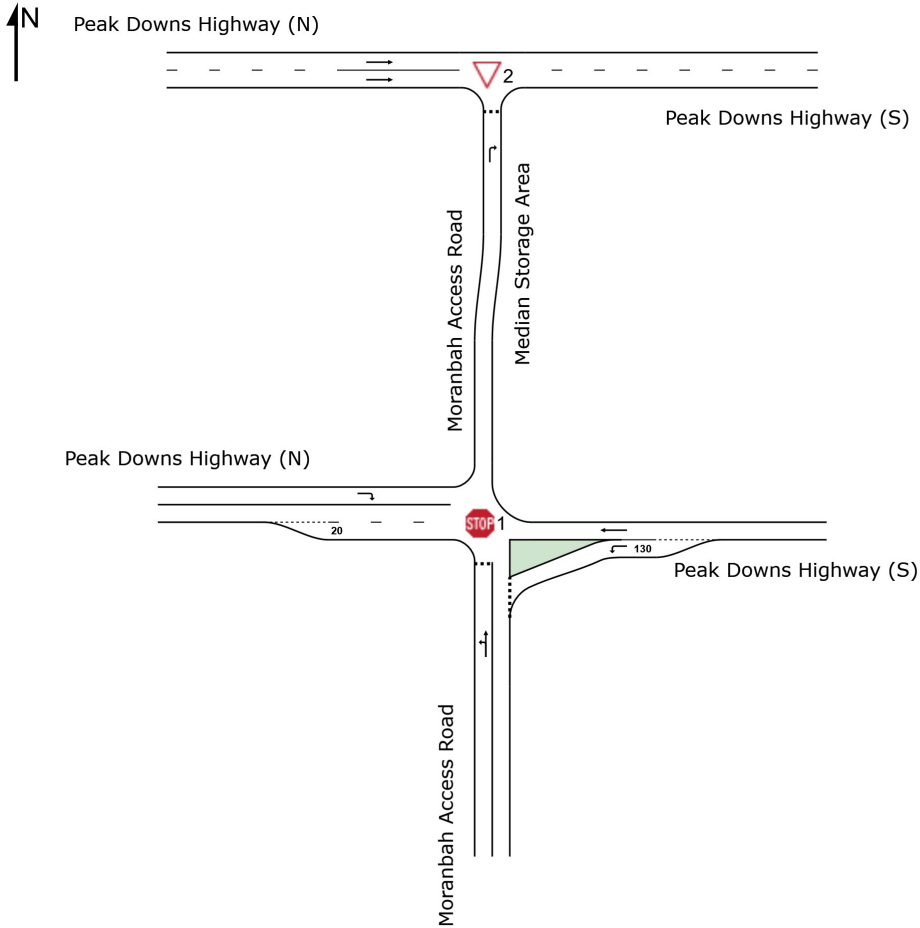

SITES IN NETWORK		
Site ID	CCG ID	Site Name
STOP 1	NA	2020AM - Base
▽ 2	NA	2020AM -Base

LANE SUMMARY

 Site: 1 [2020AM - Base]

 Network: N101 [2020 AM - Base Case]

Staged crossing Stage 1 (Minor Road) at three-way intersection with 5-lane major road. Major road turn lane is treated as a full-length lane.

Site Category: (None)

Stop (Two-Way)

Lane Use and Performance															
	Demand Flows		Arrival Flows		Cap.	Deg. Satn v/c	Lane Util. %	Average Delay sec	Level of Service	95% Back of Queue		Lane Config	Lane Length m	Cap. Adj. %	Prob. Block. %
	Total veh/h	HV %	Total veh/h	HV %						Veh	Dist m				
South: Moranbah Access Road															
Lane 1	355	11.3	355	11.3	1187	0.299	100	5.9	LOS A	1.3	10.1	Full	500	0.0	0.0
Approach	355	11.3	355	11.3		0.299		5.9	LOS A	1.3	10.1				
East: Peak Downs Highway (S)															
Lane 1	136	6.0	136	6.0	1263	0.107	100	6.1	LOS A	0.5	3.3	Short	130	0.0	NA
Lane 2	79	13.0	79	13.0	1798	0.044	100	0.0	LOS A	0.0	0.0	Full	500	0.0	0.0
Approach	215	8.6	215	8.6		0.107		3.9	LOS A	0.5	3.3				
West: Peak Downs Highway (N)															
Lane 1	93	26.0	93	26.0	1468	0.063	100	6.1	LOS A	0.3	2.5	Full	500	0.0	0.0
Approach	93	26.0	93	26.0		0.063		6.1	NA	0.3	2.5				
Intersection	662	12.4	662	12.4		0.299		5.3	NA	1.3	10.1				

Site Level of Service (LOS) Method: Delay (SIDRA). Site LOS Method is specified in the Network Data dialog (Network tab).

Lane LOS values are based on average delay per lane.

Minor Road Approach LOS values are based on average delay for all lanes.

NA: Intersection LOS and Major Road Approach LOS values are Not Applicable for two-way sign control since the average delay is not a good LOS measure due to zero delays associated with major road lanes.

SIDRA Standard Delay Model is used. Control Delay includes Geometric Delay.

Gap-Acceptance Capacity: SIDRA Standard (Akçelik M3D).

HV (%) values are calculated for All Movement Classes of All Heavy Vehicle Model Designation.

SIDRA INTERSECTION 8.0 | Copyright © 2000-2018 Akcelik and Associates Pty Ltd | sidrasolutions.com

Organisation: GTA CONSULTANTS | Processed: 27 November 2018 8:21:13 AM

Project: P:\Q12500-12599\Q125681 Olive Downs - RFI Response\Modelling\181120 - Intersection Modelling\Moranbah Access.sip8

LANE SUMMARY

Site: 2 [2020AM -Base]

Network: N101 [2020 AM - Base Case]

Staged crossing Stage 2 (Median) at three-way intersection with 5-lane major road.

Give-way behaviour assumed at Stage 2.

Site Category: (None)

Giveaway / Yield (Two-Way)

Lane Use and Performance															
	Demand Flows		Arrival Flows		Cap.	Deg. Satn v/c	Lane Util. %	Average Delay sec	Level of Service	95% Back of Queue		Lane Config	Lane Length m	Cap. Adj. %	Prob. Block. %
	Total veh/h	HV %	Total veh/h	HV %						Veh	Dist m				
South: Moranbah Access Road															
Lane 1	19817.0	198	17.0	1253	0.158	100	0.3	LOS A	0.6	3.6	Full	7	0.0	0.0	
Approach	19817.0	198	17.0		0.158		0.3	LOS A	0.6	3.6					
West: Peak Downs Highway (N)															
Lane 1	3322.0	33	22.0	1706	0.019	100	0.0	LOS A	0.0	0.0	Full	500	0.0	0.0	
Lane 2	3322.0	33	22.0	1706	0.019	100	0.0	LOS A	0.0	0.0	Full	500	0.0	0.0	
Approach	6622.0	66	22.0		0.019		0.0	NA	0.0	0.0					
Intersection	26418.3	264	18.3		0.158		0.2	NA	0.6	3.6					

Site Level of Service (LOS) Method: Delay (SIDRA). Site LOS Method is specified in the Network Data dialog (Network tab).

Lane LOS values are based on average delay per lane.

Minor Road Approach LOS values are based on average delay for all lanes.

NA: Intersection LOS and Major Road Approach LOS values are Not Applicable for two-way sign control since the average delay is not a good LOS measure due to zero delays associated with major road lanes.

SIDRA Standard Delay Model is used. Control Delay includes Geometric Delay.

Gap-Acceptance Capacity: SIDRA Standard (Akçelik M3D).

HV (%) values are calculated for All Movement Classes of All Heavy Vehicle Model Designation.

SIDRA INTERSECTION 8.0 | Copyright © 2000-2018 Akcelik and Associates Pty Ltd | sidrasolutions.com

Organisation: GTA CONSULTANTS | Processed: 27 November 2018 8:21:13 AM

Project: P:\Q12500-12599\Q125681 Olive Downs - RFI Response\Modelling\181120 - Intersection Modelling\Moranbah Access.sip8

NETWORK LAYOUT

Network: N101 [2028 AM - Base Case]

New Network
 Network Category: (None)

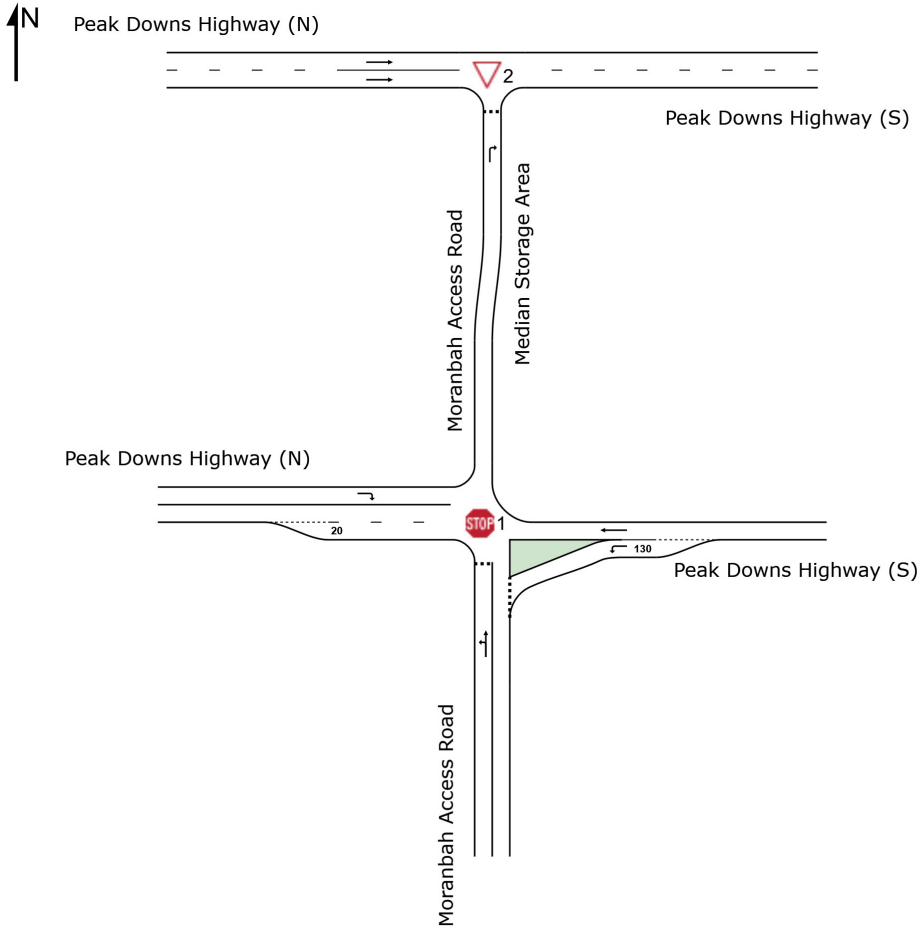

SITES IN NETWORK		
Site ID	CCG ID	Site Name
STOP 1	NA	2028AM - Base
▽ 2	NA	2028AM -Base

LANE SUMMARY

 Site: 1 [2028AM - Base]

 Network: N101 [2028 AM - Base Case]

Staged crossing Stage 1 (Minor Road) at three-way intersection with 5-lane major road. Major road turn lane is treated as a full-length lane.

Site Category: (None)

Stop (Two-Way)

Lane Use and Performance															
	Demand Flows		Arrival Flows		Cap.	Deg. Satn v/c	Lane Util. %	Average Delay sec	Level of Service	95% Back of Queue		Lane Config	Lane Length m	Cap. Adj. %	Prob. Block. %
	Total veh/h	HV %	Total veh/h	HV %						Veh	Dist m				
South: Moranbah Access Road															
Lane 1	408	11.2	408	11.2	1155	0.354	100	6.1	LOS A	1.6	12.5	Full	500	0.0	0.0
Approach	408	11.2	408	11.2		0.354		6.1	LOS A	1.6	12.5				
East: Peak Downs Highway (S)															
Lane 1	157	6.0	157	6.0	1243	0.126	100	6.2	LOS A	0.5	3.9	Short	130	0.0	NA
Lane 2	92	13.0	92	13.0	1798	0.051	100	0.0	LOS A	0.0	0.0	Full	500	0.0	0.0
Approach	248	8.6	248	8.6		0.126		3.9	LOS A	0.5	3.9				
West: Peak Downs Highway (N)															
Lane 1	106	26.0	106	26.0	1448	0.073	100	6.2	LOS A	0.3	2.9	Full	500	0.0	0.0
Approach	106	26.0	106	26.0		0.073		6.2	NA	0.3	2.9				
Intersection	763	12.4	763	12.4		0.354		5.4	NA	1.6	12.5				

Site Level of Service (LOS) Method: Delay (SIDRA). Site LOS Method is specified in the Network Data dialog (Network tab).

Lane LOS values are based on average delay per lane.

Minor Road Approach LOS values are based on average delay for all lanes.

NA: Intersection LOS and Major Road Approach LOS values are Not Applicable for two-way sign control since the average delay is not a good LOS measure due to zero delays associated with major road lanes.

SIDRA Standard Delay Model is used. Control Delay includes Geometric Delay.

Gap-Acceptance Capacity: SIDRA Standard (Akçelik M3D).

HV (%) values are calculated for All Movement Classes of All Heavy Vehicle Model Designation.

LANE SUMMARY

Site: 2 [2028AM -Base]

Network: N101 [2028 AM - Base Case]

Staged crossing Stage 2 (Median) at three-way intersection with 5-lane major road.

Give-way behaviour assumed at Stage 2.

Site Category: (None)

Giveaway / Yield (Two-Way)

Lane Use and Performance															
	Demand		Arrival Flows		Cap.	Deg. Satn	Lane Util.	Average Delay	Level of Service	95% Back of Queue		Lane Config	Lane Length	Cap. Adj.	Prob. Block.
	Total veh/h	HV %	Total veh/h	HV %						Veh	Dist m				
South: Moranbah Access Road															
Lane 1	227	17.0	227	17.0	1242	0.183	100	0.3	LOS A	0.7	4.3	Full	7	0.0	0.0
Approach	227	17.0	227	17.0		0.183		0.3	LOS A	0.7	4.3				
West: Peak Downs Highway (N)															
Lane 1	3822.0	38	22.0	1706	0.022	100	0.0	LOS A	0.0	0.0	Full	500	0.0	0.0	
Lane 2	3822.0	38	22.0	1706	0.022	100	0.0	LOS A	0.0	0.0	Full	500	0.0	0.0	
Approach	7622.0	76	22.0		0.022		0.0	NA	0.0	0.0					
Intersection	303	18.3	303	18.3		0.183		0.2	NA	0.7	4.3				

Site Level of Service (LOS) Method: Delay (SIDRA). Site LOS Method is specified in the Network Data dialog (Network tab).

Lane LOS values are based on average delay per lane.

Minor Road Approach LOS values are based on average delay for all lanes.

NA: Intersection LOS and Major Road Approach LOS values are Not Applicable for two-way sign control since the average delay is not a good LOS measure due to zero delays associated with major road lanes.

SIDRA Standard Delay Model is used. Control Delay includes Geometric Delay.

Gap-Acceptance Capacity: SIDRA Standard (Akçelik M3D).

HV (%) values are calculated for All Movement Classes of All Heavy Vehicle Model Designation.

SIDRA INTERSECTION 8.0 | Copyright © 2000-2018 Akcelik and Associates Pty Ltd | sidrasolutions.com

Organisation: GTA CONSULTANTS | Processed: 27 November 2018 8:21:15 AM

Project: P:\Q12500-12599\Q125681 Olive Downs - RFI Response\Modelling\181120 - Intersection Modelling\Moranbah Access.sip8

NETWORK LAYOUT

Network: N101 [2020 AM - Base + Project Case]

New Network

Network Category: (None)

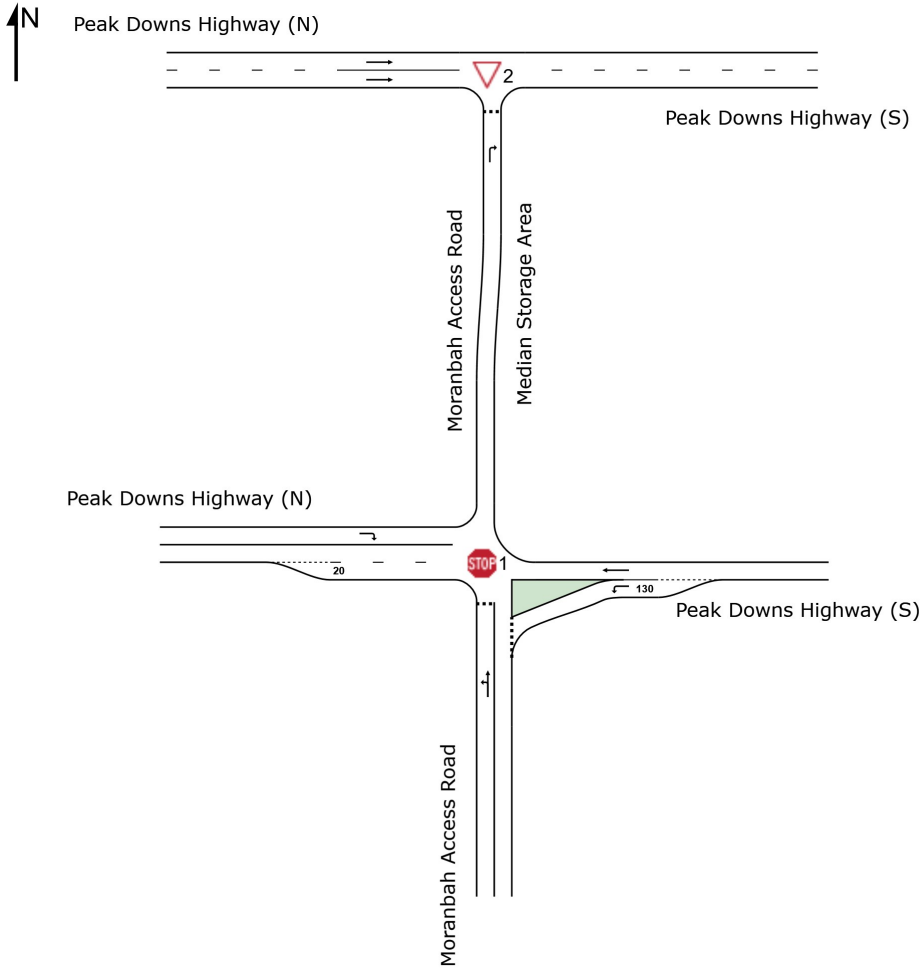

SITES IN NETWORK

Site ID	CCG ID	Site Name
STOP 1	NA	2020AM - Base+Project
▽ 2	NA	2020AM -Base + Project

SIDRA INTERSECTION 8.0 | Copyright © 2000-2018 Akcelik and Associates Pty Ltd | sidrasolutions.com

Organisation: GTA CONSULTANTS | Created: 3 December 2018 4:03:07 PM

Project: P:\Q12500-12599\Q125681 Olive Downs - RFI Response\Modelling\181120 - Intersection Modelling\Moranbah Access.sip8

LANE SUMMARY

 Site: 1 [2020AM - Base+Project]

 Network: N101 [2020 AM - Base + Project Case]

Staged crossing Stage 1 (Minor Road) at three-way intersection with 5-lane major road. Major road turn lane is treated as a full-length lane.

Site Category: (None)

Stop (Two-Way)

Lane Use and Performance															
	Demand Flows		Arrival Flows		Cap.	Deg. Satn v/c	Lane Util. %	Average Delay sec	Level of Service	95% Back of Queue		Lane Config	Lane Length m	Cap. Adj. %	Prob. Block. %
	Total veh/h	HV %	Total veh/h	HV %						Veh	Dist m				
South: Moranbah Access Road															
Lane 1	589	8.4	589	8.4	1140	0.517	100	7.5	LOS A	3.9	29.5	Full	500	0.0	0.0
Approach	589	8.4	589	8.4				7.5	LOS A	3.9	29.5				
East: Peak Downs Highway (S)															
Lane 1	136	6.0	136	6.0	935	0.145	100	7.6	LOS A	0.6	4.3	Short	130	0.0	NA
Lane 2	7913.0	79	13.0	1798	0.044	100	0.0	0.0	LOS A	0.0	0.0	Full	500	0.0	0.0
Approach	215	8.6	215	8.6		0.145		4.8	LOS A	0.6	4.3				
West: Peak Downs Highway (N)															
Lane 1	32726.0	327	26.0	1468	0.223	100	6.2	6.2	LOS A	1.2	10.3	Full	500	0.0	0.0
Approach	32726.0	327	26.0			0.223		6.2	NA	1.2	10.3				
Intersection	113213.5	1132	13.5			0.517		6.6	NA	3.9	29.5				

Site Level of Service (LOS) Method: Delay (SIDRA). Site LOS Method is specified in the Network Data dialog (Network tab).

Lane LOS values are based on average delay per lane.

Minor Road Approach LOS values are based on average delay for all lanes.

NA: Intersection LOS and Major Road Approach LOS values are Not Applicable for two-way sign control since the average delay is not a good LOS measure due to zero delays associated with major road lanes.

SIDRA Standard Delay Model is used. Control Delay includes Geometric Delay.

Gap-Acceptance Capacity: SIDRA Standard (Akçelik M3D).

HV (%) values are calculated for All Movement Classes of All Heavy Vehicle Model Designation.

SIDRA INTERSECTION 8.0 | Copyright © 2000-2018 Akcelik and Associates Pty Ltd | sidrasolutions.com

Organisation: GTA CONSULTANTS | Processed: 27 November 2018 8:21:17 AM

Project: P:\Q12500-12599\Q125681 Olive Downs - RFI Response\Modelling\181120 - Intersection Modelling\Moranbah Access.sip8

LANE SUMMARY

Site: 2 [2020AM -Base + Project]

Network: N101 [2020 AM - Base + Project Case]

Staged crossing Stage 2 (Median) at three-way intersection with 5-lane major road.

Give-way behaviour assumed at Stage 2.

Site Category: (None)

Giveaway / Yield (Two-Way)

Lane Use and Performance															
	Demand Flows		Arrival Flows		Cap.	Deg. Satn v/c	Lane Util. %	Average Delay sec	Level of Service	95% Back of Queue		Lane Config	Lane Length m	Cap. Adj. %	Prob. Block. %
	Total veh/h	HV %	Total veh/h	HV %						Veh	Dist m				
South: Moranbah Access Road															
Lane 1	19817.0	198	17.0	1253	0.158	100	0.3	LOS A	0.6	3.6	Full	7	0.0	0.0	
Approach	19817.0	198	17.0		0.158		0.3	LOS A	0.6	3.6					
West: Peak Downs Highway (N)															
Lane 1	3322.0	33	22.0	1706	0.019	100	0.0	LOS A	0.0	0.0	Full	500	0.0	0.0	
Lane 2	3322.0	33	22.0	1706	0.019	100	0.0	LOS A	0.0	0.0	Full	500	0.0	0.0	
Approach	6622.0	66	22.0		0.019		0.0	NA	0.0	0.0					
Intersection	26418.3	264	18.3		0.158		0.2	NA	0.6	3.6					

Site Level of Service (LOS) Method: Delay (SIDRA). Site LOS Method is specified in the Network Data dialog (Network tab).

Lane LOS values are based on average delay per lane.

Minor Road Approach LOS values are based on average delay for all lanes.

NA: Intersection LOS and Major Road Approach LOS values are Not Applicable for two-way sign control since the average delay is not a good LOS measure due to zero delays associated with major road lanes.

SIDRA Standard Delay Model is used. Control Delay includes Geometric Delay.

Gap-Acceptance Capacity: SIDRA Standard (Akçelik M3D).

HV (%) values are calculated for All Movement Classes of All Heavy Vehicle Model Designation.

SIDRA INTERSECTION 8.0 | Copyright © 2000-2018 Akcelik and Associates Pty Ltd | sidrasolutions.com

Organisation: GTA CONSULTANTS | Processed: 27 November 2018 8:21:17 AM

Project: P:\Q12500-12599\Q125681 Olive Downs - RFI Response\Modelling\181120 - Intersection Modelling\Moranbah Access.sip8

NETWORK LAYOUT

Network: N101 [2028 AM - Base + Project Case]

New Network
 Network Category: (None)

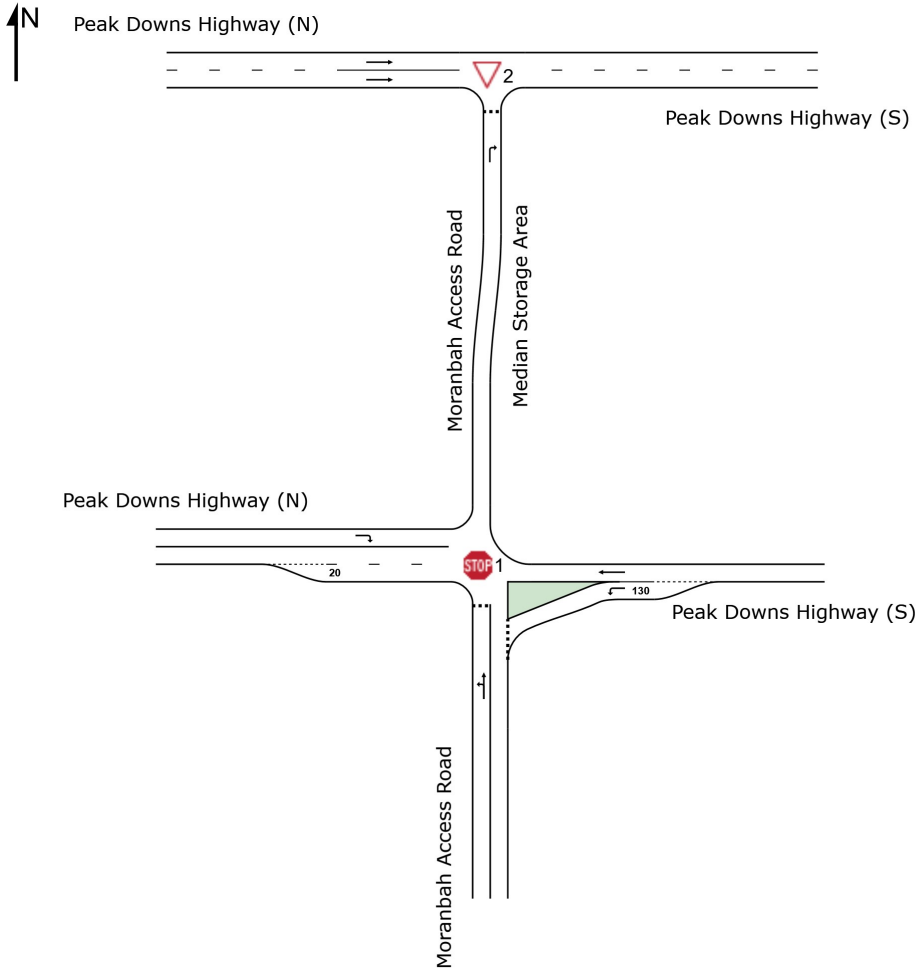

SITES IN NETWORK		
Site ID	CCG ID	Site Name
STOP 1	NA	2028AM - Base+Project
▽ 2	NA	2028AM -Base + Project

LANE SUMMARY

 Site: 1 [2028AM - Base+Project]

 Network: N101 [2028 AM - Base + Project Case]

Staged crossing Stage 1 (Minor Road) at three-way intersection with 5-lane major road. Major road turn lane is treated as a full-length lane.

Site Category: (None)

Stop (Two-Way)

Lane Use and Performance															
	Demand Flows		Arrival Flows		Cap.	Deg. Satn v/c	Lane Util. %	Average Delay sec	Level of Service	95% Back of Queue		Lane Config	Lane Length m	Cap. Adj. %	Prob. Block. %
	Total veh/h	HV %	Total veh/h	HV %						Veh	Dist m				
South: Moranbah Access Road															
Lane 1	641	8.6	641	8.6	1096	0.585	100	8.4	LOS A	5.4	40.4	Full	500	0.0	0.0
Approach	641	8.6	641	8.6		0.585		8.4	LOS A	5.4	40.4				
East: Peak Downs Highway (S)															
Lane 1	157	6.0	157	6.0	920	0.171	100	7.8	LOS A	0.7	5.1	Short	130	0.0	NA
Lane 2	92	13.0	92	13.0	1798	0.051	100	0.0	LOS A	0.0	0.0	Full	500	0.0	0.0
Approach	248	8.6	248	8.6		0.171		4.9	LOS A	0.7	5.1				
West: Peak Downs Highway (N)															
Lane 1	339	26.0	339	26.0	1448	0.234	100	6.3	LOS A	1.3	10.8	Full	500	0.0	0.0
Approach	339	26.0	339	26.0		0.234		6.3	NA	1.3	10.8				
Intersection	1228	13.4	1228	13.4		0.585		7.1	NA	5.4	40.4				

Site Level of Service (LOS) Method: Delay (SIDRA). Site LOS Method is specified in the Network Data dialog (Network tab).

Lane LOS values are based on average delay per lane.

Minor Road Approach LOS values are based on average delay for all lanes.

NA: Intersection LOS and Major Road Approach LOS values are Not Applicable for two-way sign control since the average delay is not a good LOS measure due to zero delays associated with major road lanes.

SIDRA Standard Delay Model is used. Control Delay includes Geometric Delay.

Gap-Acceptance Capacity: SIDRA Standard (Akçelik M3D).

HV (%) values are calculated for All Movement Classes of All Heavy Vehicle Model Designation.

LANE SUMMARY

Site: 2 [2028AM -Base + Project]

Network: N101 [2028 AM - Base + Project Case]

Staged crossing Stage 2 (Median) at three-way intersection with 5-lane major road.

Give-way behaviour assumed at Stage 2.

Site Category: (None)

Giveaway / Yield (Two-Way)

Lane Use and Performance															
	Demand Flows		Arrival Flows		Cap.	Deg. Satn v/c	Lane Util. %	Average Delay sec	Level of Service	95% Back of Queue		Lane Config	Lane Length m	Cap. Adj. %	Prob. Block. %
	Total veh/h	HV %	Total veh/h	HV %						Veh	Dist m				
South: Moranbah Access Road															
Lane 1	227	17.0	227	17.0	1242	0.183	100	0.3	LOS A	0.7	4.3	Full	7	0.0	0.0
Approach	227	17.0	227	17.0		0.183		0.3	LOS A	0.7	4.3				
West: Peak Downs Highway (N)															
Lane 1	3822.0	38	22.0	1706	0.022	100	0.0	LOS A	0.0	0.0	Full	500	0.0	0.0	
Lane 2	3822.0	38	22.0	1706	0.022	100	0.0	LOS A	0.0	0.0	Full	500	0.0	0.0	
Approach	7622.0	76	22.0		0.022		0.0	NA	0.0	0.0					
Intersection	303	18.3	303	18.3		0.183		0.2	NA	0.7	4.3				

Site Level of Service (LOS) Method: Delay (SIDRA). Site LOS Method is specified in the Network Data dialog (Network tab).

Lane LOS values are based on average delay per lane.

Minor Road Approach LOS values are based on average delay for all lanes.

NA: Intersection LOS and Major Road Approach LOS values are Not Applicable for two-way sign control since the average delay is not a good LOS measure due to zero delays associated with major road lanes.

SIDRA Standard Delay Model is used. Control Delay includes Geometric Delay.

Gap-Acceptance Capacity: SIDRA Standard (Akçelik M3D).

HV (%) values are calculated for All Movement Classes of All Heavy Vehicle Model Designation.

NETWORK LAYOUT

Network: N101 [2020 PM - Base Case]

New Network
 Network Category: (None)

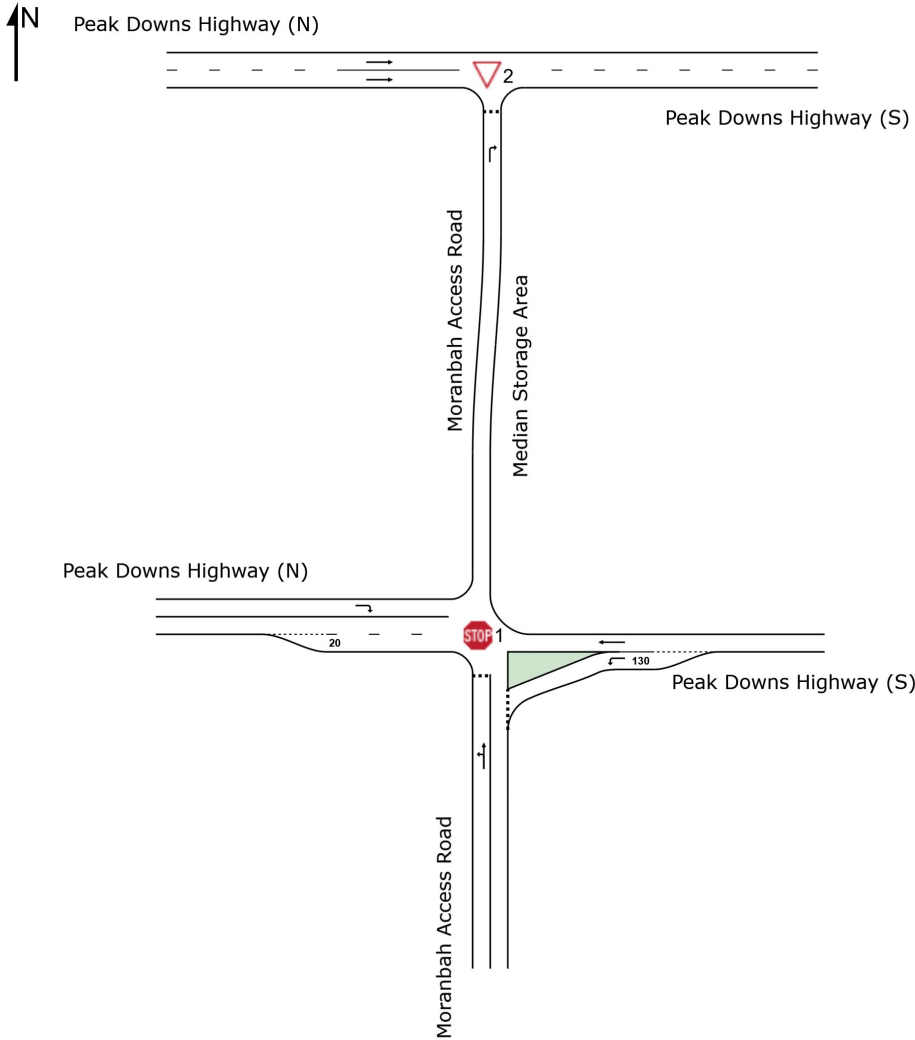

SITES IN NETWORK

Site ID	CCG ID	Site Name
STOP 1	NA	2020PM - Base
▽ 2	NA	2020PM -Base

SIDRA INTERSECTION 8.0 | Copyright © 2000-2018 Akcelik and Associates Pty Ltd | sidrasolutions.com

Organisation: GTA CONSULTANTS | Created: 3 December 2018 4:05:31 PM

Project: P:\Q12500-12599\Q125681 Olive Downs - RFI Response\Modelling\181120 - Intersection Modelling\Morambah Access.sip8

LANE SUMMARY

 Site: 1 [2020PM - Base]

 Network: N101 [2020 PM - Base Case]

Staged crossing Stage 1 (Minor Road) at three-way intersection with 5-lane major road. Major road turn lane is treated as a full-length lane.

Site Category: (None)

Stop (Two-Way)

Lane Use and Performance															
	Demand Flows		Arrival Flows		Cap.	Deg. Satn v/c	Lane Util. %	Average Delay sec	Level of Service	95% Back of Queue		Lane Config	Lane Length m	Cap. Adj. %	Prob. Block. %
	Total veh/h	HV %	Total veh/h	HV %						Veh	Dist m				
South: Moranbah Access Road															
Lane 1	239	8.3	239	8.3	1125	0.212	100	6.0	LOS A	0.8	6.3	Full	500	0.0	0.0
Approach	239	8.3	239	8.3		0.212		6.0	LOS A	0.8	6.3				
East: Peak Downs Highway (S)															
Lane 1	293	8.0	293	8.0	1169	0.250	100	6.6	LOS A	1.2	8.8	Short	130	0.0	NA
Lane 2	5453.0	54	53.0	1450	0.037	100	0.0	0.0	LOS A	0.0	0.0	Full	500	0.0	0.0
Approach	34615.0	346	15.0			0.250		5.6	LOS A	1.2	8.8				
West: Peak Downs Highway (N)															
Lane 1	162	8.0	162	8.0	1629	0.099	100	5.8	LOS A	0.5	3.6	Full	500	0.0	0.0
Approach	162	8.0	162	8.0		0.099		5.8	NA	0.5	3.6				
Intersection	747	11.3	747	11.3		0.250		5.8	NA	1.2	8.8				

Site Level of Service (LOS) Method: Delay (SIDRA). Site LOS Method is specified in the Network Data dialog (Network tab).

Lane LOS values are based on average delay per lane.

Minor Road Approach LOS values are based on average delay for all lanes.

NA: Intersection LOS and Major Road Approach LOS values are Not Applicable for two-way sign control since the average delay is not a good LOS measure due to zero delays associated with major road lanes.

SIDRA Standard Delay Model is used. Control Delay includes Geometric Delay.

Gap-Acceptance Capacity: SIDRA Standard (Akçelik M3D).

HV (%) values are calculated for All Movement Classes of All Heavy Vehicle Model Designation.

SIDRA INTERSECTION 8.0 | Copyright © 2000-2018 Akcelik and Associates Pty Ltd | sidrasolutions.com

Organisation: GTA CONSULTANTS | Processed: 27 November 2018 8:21:22 AM

Project: P:\Q12500-12599\Q125681 Olive Downs - RFI Response\Modelling\181120 - Intersection Modelling\Moranbah Access.sip8

LANE SUMMARY

Site: 2 [2020PM -Base]

Network: N101 [2020 PM - Base Case]

Staged crossing Stage 2 (Median) at three-way intersection with 5-lane major road.

Give-way behaviour assumed at Stage 2.

Site Category: (None)

Giveaway / Yield (Two-Way)

Lane Use and Performance															
	Demand		Arrival Flows		Cap.	Deg. Satn	Lane Util.	Average Delay	Level of Service	95% Back of Queue		Lane Config	Lane Length	Cap. Adj.	Prob. Block.
	Total veh/h	HV %	Total veh/h	HV %						Veh	Dist m				
South: Moranbah Access Road															
Lane 1	141	5.0	141	5.0	1346	0.105	100	0.2	LOS A	0.4	2.0	Full	7	0.0	0.0
Approach	141	5.0	141	5.0		0.105		0.2	LOS A	0.4	2.0				
West: Peak Downs Highway (N)															
Lane 1	2621.0	26	21.0	1716	0.015	100	0.0	LOS A	0.0	0.0	0.0	Full	500	0.0	0.0
Lane 2	2621.0	26	21.0	1716	0.015	100	0.0	LOS A	0.0	0.0	0.0	Full	500	0.0	0.0
Approach	5321.0	53	21.0		0.015		0.0	NA	0.0	0.0					
Intersection	194	9.3	194	9.3		0.105		0.1	NA	0.4	2.0				

Site Level of Service (LOS) Method: Delay (SIDRA). Site LOS Method is specified in the Network Data dialog (Network tab).

Lane LOS values are based on average delay per lane.

Minor Road Approach LOS values are based on average delay for all lanes.

NA: Intersection LOS and Major Road Approach LOS values are Not Applicable for two-way sign control since the average delay is not a good LOS measure due to zero delays associated with major road lanes.

SIDRA Standard Delay Model is used. Control Delay includes Geometric Delay.

Gap-Acceptance Capacity: SIDRA Standard (Akçelik M3D).

HV (%) values are calculated for All Movement Classes of All Heavy Vehicle Model Designation.

SIDRA INTERSECTION 8.0 | Copyright © 2000-2018 Akcelik and Associates Pty Ltd | sidrasolutions.com

Organisation: GTA CONSULTANTS | Processed: 27 November 2018 8:21:22 AM

Project: P:\Q12500-12599\Q125681 Olive Downs - RFI Response\Modelling\181120 - Intersection Modelling\Moranbah Access.sip8

NETWORK LAYOUT

Network: N101 [2028 PM - Base Case]

New Network
 Network Category: (None)

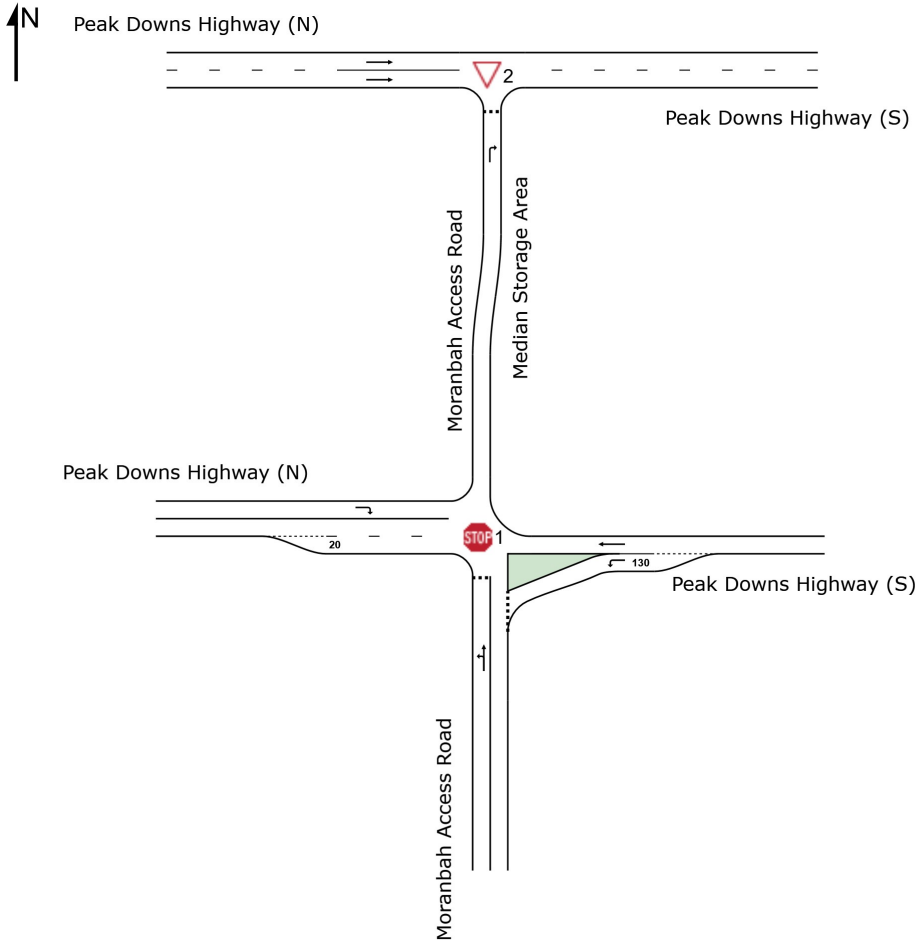

SITES IN NETWORK		
Site ID	CCG ID	Site Name
STOP 1	NA	2028PM - Base
▽ 2	NA	2028PM -Base

LANE SUMMARY

 Site: 1 [2028PM - Base]

 Network: N101 [2028 PM - Base Case]

Staged crossing Stage 1 (Minor Road) at three-way intersection with 5-lane major road. Major road turn lane is treated as a full-length lane.

Site Category: (None)

Stop (Two-Way)

Lane Use and Performance															
	Demand Flows		Arrival Flows		Cap.	Deg. Satn v/c	Lane Util. %	Average Delay sec	Level of Service	95% Back of Queue		Lane Config	Lane Length m	Cap. Adj. %	Prob. Block. %
	Total veh/h	HV %	Total veh/h	HV %						Veh	Dist m				
South: Moranbah Access Road															
Lane 1	275	8.3	275	8.3	1080	0.254	100	6.3	LOS A	1.0	7.8	Full	500	0.0	0.0
Approach	275	8.3	275	8.3		0.254		6.3	LOS A	1.0	7.8				
East: Peak Downs Highway (S)															
Lane 1	338	8.0	338	8.0	1136	0.297	100	6.8	LOS A	1.4	10.8	Short	130	0.0	NA
Lane 2	6253.0	62	53.0	1450	0.043	100	0.0	0.0	LOS A	0.0	0.0	Full	500	0.0	0.0
Approach	40015.0	400	15.0			0.297		5.8	LOS A	1.4	10.8				
West: Peak Downs Highway (N)															
Lane 1	187	8.0	187	8.0	1614	0.116	100	5.9	LOS A	0.6	4.2	Full	500	0.0	0.0
Approach	187	8.0	187	8.0		0.116		5.9	NA	0.6	4.2				
Intersection	862	11.3	862	11.3		0.297		5.9	NA	1.4	10.8				

Site Level of Service (LOS) Method: Delay (SIDRA). Site LOS Method is specified in the Network Data dialog (Network tab).

Lane LOS values are based on average delay per lane.

Minor Road Approach LOS values are based on average delay for all lanes.

NA: Intersection LOS and Major Road Approach LOS values are Not Applicable for two-way sign control since the average delay is not a good LOS measure due to zero delays associated with major road lanes.

SIDRA Standard Delay Model is used. Control Delay includes Geometric Delay.

Gap-Acceptance Capacity: SIDRA Standard (Akçelik M3D).

HV (%) values are calculated for All Movement Classes of All Heavy Vehicle Model Designation.

SIDRA INTERSECTION 8.0 | Copyright © 2000-2018 Akcelik and Associates Pty Ltd | sidrasolutions.com

Organisation: GTA CONSULTANTS | Processed: 27 November 2018 8:21:24 AM

Project: P:\Q12500-12599\Q125681 Olive Downs - RFI Response\Modelling\181120 - Intersection Modelling\Moranbah Access.sip8

LANE SUMMARY

Site: 2 [2028PM -Base]

Network: N101 [2028 PM - Base Case]

Staged crossing Stage 2 (Median) at three-way intersection with 5-lane major road.

Give-way behaviour assumed at Stage 2.

Site Category: (None)

Giveaway / Yield (Two-Way)

Lane Use and Performance															
	Demand Flows		Arrival Flows		Cap.	Deg. Satn v/c	Lane Util. %	Average Delay sec	Level of Service	95% Back of Queue		Lane Config	Lane Length m	Cap. Adj. %	Prob. Block. %
	Total veh/h	HV %	Total veh/h	HV %						Veh	Dist m				
South: Moranbah Access Road															
Lane 1	162	5.0	162	5.0	1337	0.121	100	0.2	LOS A	0.4	2.4	Full	7	0.0	0.0
Approach	162	5.0	162	5.0		0.121		0.2	LOS A	0.4	2.4				
West: Peak Downs Highway (N)															
Lane 1	3121.0	31	21.0	1716	0.018	0.018	100	0.0	LOS A	0.0	0.0	Full	500	0.0	0.0
Lane 2	3121.0	31	21.0	1716	0.018	0.018	100	0.0	LOS A	0.0	0.0	Full	500	0.0	0.0
Approach	6121.0	61	21.0			0.018		0.0	NA	0.0	0.0				
Intersection	223	9.4	223	9.4		0.121		0.1	NA	0.4	2.4				

Site Level of Service (LOS) Method: Delay (SIDRA). Site LOS Method is specified in the Network Data dialog (Network tab).

Lane LOS values are based on average delay per lane.

Minor Road Approach LOS values are based on average delay for all lanes.

NA: Intersection LOS and Major Road Approach LOS values are Not Applicable for two-way sign control since the average delay is not a good LOS measure due to zero delays associated with major road lanes.

SIDRA Standard Delay Model is used. Control Delay includes Geometric Delay.

Gap-Acceptance Capacity: SIDRA Standard (Akçelik M3D).

HV (%) values are calculated for All Movement Classes of All Heavy Vehicle Model Designation.

SIDRA INTERSECTION 8.0 | Copyright © 2000-2018 Akcelik and Associates Pty Ltd | sidrasolutions.com

Organisation: GTA CONSULTANTS | Processed: 27 November 2018 8:21:24 AM

Project: P:\Q12500-12599\Q125681 Olive Downs - RFI Response\Modelling\181120 - Intersection Modelling\Moranbah Access.sip8

NETWORK LAYOUT

Network: N101 [2020 PM - Base + Project Case]

New Network

Network Category: (None)

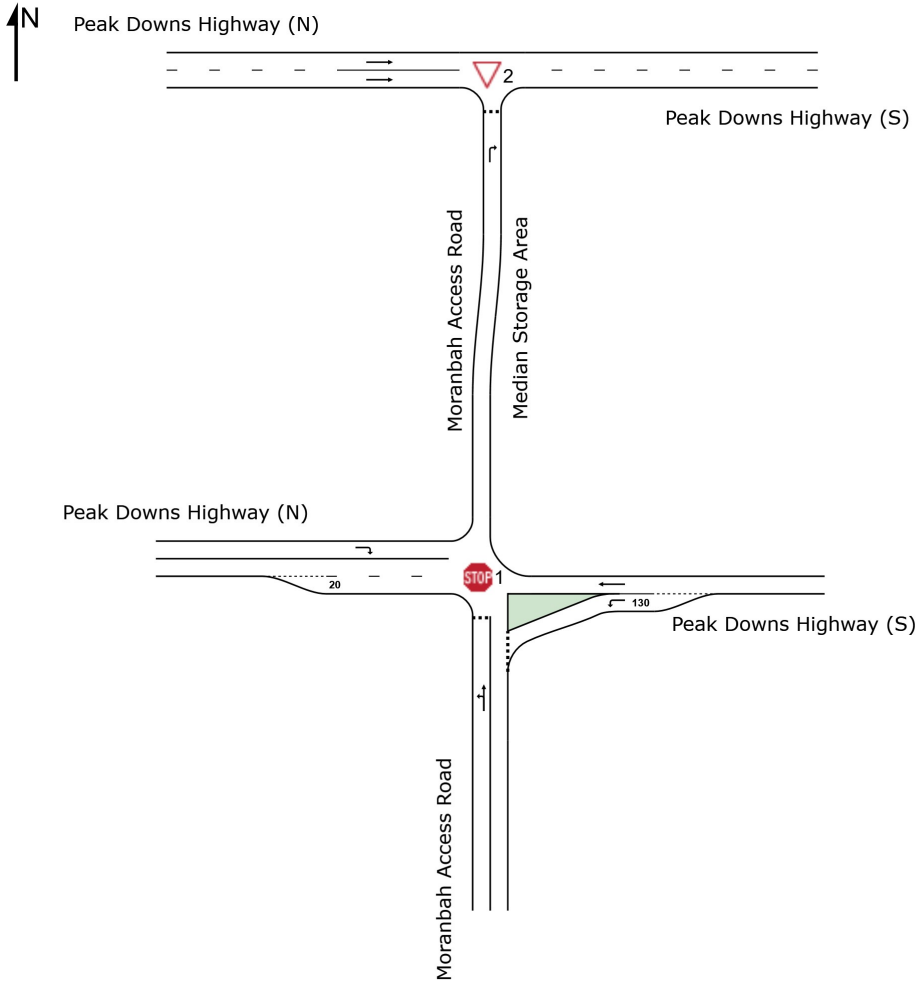

SITES IN NETWORK		
Site ID	CCG ID	Site Name
STOP 1	NA	2020PM - Base+Project
▽ 2	NA	2020PM -Base+Project

SIDRA INTERSECTION 8.0 | Copyright © 2000-2018 Akcelik and Associates Pty Ltd | sidrasolutions.com

Organisation: GTA CONSULTANTS | Created: 3 December 2018 4:07:38 PM

Project: P:\Q12500-12599\Q125681 Olive Downs - RFI Response\Modelling\181120 - Intersection Modelling\Moranbah Access.sip8

LANE SUMMARY

 Site: 1 [2020PM - Base+Project]

 Network: N101 [2020 PM - Base + Project Case]

Staged crossing Stage 1 (Minor Road) at three-way intersection with 5-lane major road. Major road turn lane is treated as a full-length lane.

Site Category: (None)

Stop (Two-Way)

Lane Use and Performance															
	Demand Flows		Arrival Flows		Cap.	Deg. Satn v/c	Lane Util. %	Average Delay sec	Level of Service	95% Back of Queue		Lane Config	Lane Length m	Cap. Adj. %	Prob. Block. %
	Total veh/h	HV %	Total veh/h	HV %						Veh	Dist m				
South: Moranbah Access Road															
Lane 1	474	10.6	474	10.6	1138	0.416	100	6.9	LOS A	2.3	17.3	Full	500	0.0	0.0
Approach	474	10.6	474	10.6		0.416		6.9	LOS A	2.3	17.3				
East: Peak Downs Highway (S)															
Lane 1	293	8.0	293	8.0	872	0.336	100	8.7	LOS A	1.7	12.7	Short	130	0.0	NA
Lane 2	54	53.0	54	53.0	1450	0.037	100	0.0	LOS A	0.0	0.0	Full	500	0.0	0.0
Approach	346	15.0	346	15.0		0.336		7.4	LOS A	1.7	12.7				
West: Peak Downs Highway (N)															
Lane 1	397	8.0	397	8.0	1629	0.244	100	5.9	LOS A	1.3	10.0	Full	500	0.0	0.0
Approach	397	8.0	397	8.0		0.244		5.9	NA	1.3	10.0				
Intersection	1217	11.0	1217	11.0		0.416		6.7	NA	2.3	17.3				

Site Level of Service (LOS) Method: Delay (SIDRA). Site LOS Method is specified in the Network Data dialog (Network tab).

Lane LOS values are based on average delay per lane.

Minor Road Approach LOS values are based on average delay for all lanes.

NA: Intersection LOS and Major Road Approach LOS values are Not Applicable for two-way sign control since the average delay is not a good LOS measure due to zero delays associated with major road lanes.

SIDRA Standard Delay Model is used. Control Delay includes Geometric Delay.

Gap-Acceptance Capacity: SIDRA Standard (Akçelik M3D).

HV (%) values are calculated for All Movement Classes of All Heavy Vehicle Model Designation.

SIDRA INTERSECTION 8.0 | Copyright © 2000-2018 Akcelik and Associates Pty Ltd | sidrasolutions.com

Organisation: GTA CONSULTANTS | Processed: 27 November 2018 8:21:27 AM

Project: P:\Q12500-12599\Q125681 Olive Downs - RFI Response\Modelling\181120 - Intersection Modelling\Moranbah Access.sip8

LANE SUMMARY

Site: 2 [2020PM -Base+Project]

Network: N101 [2020 PM - Base + Project Case]

Staged crossing Stage 2 (Median) at three-way intersection with 5-lane major road.

Give-way behaviour assumed at Stage 2.

Site Category: (None)

Giveaway / Yield (Two-Way)

Lane Use and Performance															
	Demand Flows		Arrival Flows		Cap.	Deg. Satn v/c	Lane Util. %	Average Delay sec	Level of Service	95% Back of Queue		Lane Config	Lane Length m	Cap. Adj. %	Prob. Block. %
	Total veh/h	HV %	Total veh/h	HV %						Veh	Dist m				
South: Moranbah Access Road															
Lane 1	141	5.0	141	5.0	1346	0.105	100	0.2	LOS A	0.4	2.0	Full	7	0.0	0.0
Approach	141	5.0	141	5.0		0.105		0.2	LOS A	0.4	2.0				
West: Peak Downs Highway (N)															
Lane 1	2621.0	26	21.0	1716	0.015	100	0.0	0.0	LOS A	0.0	0.0	Full	500	0.0	0.0
Lane 2	2621.0	26	21.0	1716	0.015	100	0.0	0.0	LOS A	0.0	0.0	Full	500	0.0	0.0
Approach	5321.0	53	21.0		0.015		0.0	0.0	NA	0.0	0.0				
Intersection	194	9.3	194	9.3		0.105		0.1	NA	0.4	2.0				

Site Level of Service (LOS) Method: Delay (SIDRA). Site LOS Method is specified in the Network Data dialog (Network tab).

Lane LOS values are based on average delay per lane.

Minor Road Approach LOS values are based on average delay for all lanes.

NA: Intersection LOS and Major Road Approach LOS values are Not Applicable for two-way sign control since the average delay is not a good LOS measure due to zero delays associated with major road lanes.

SIDRA Standard Delay Model is used. Control Delay includes Geometric Delay.

Gap-Acceptance Capacity: SIDRA Standard (Akçelik M3D).

HV (%) values are calculated for All Movement Classes of All Heavy Vehicle Model Designation.

SIDRA INTERSECTION 8.0 | Copyright © 2000-2018 Akcelik and Associates Pty Ltd | sidrasolutions.com

Organisation: GTA CONSULTANTS | Processed: 27 November 2018 8:21:27 AM

Project: P:\Q12500-12599\Q125681 Olive Downs - RFI Response\Modelling\181120 - Intersection Modelling\Moranbah Access.sip8

NETWORK LAYOUT

Network: N101 [2028 PM - Base + Project Case]

New Network
 Network Category: (None)

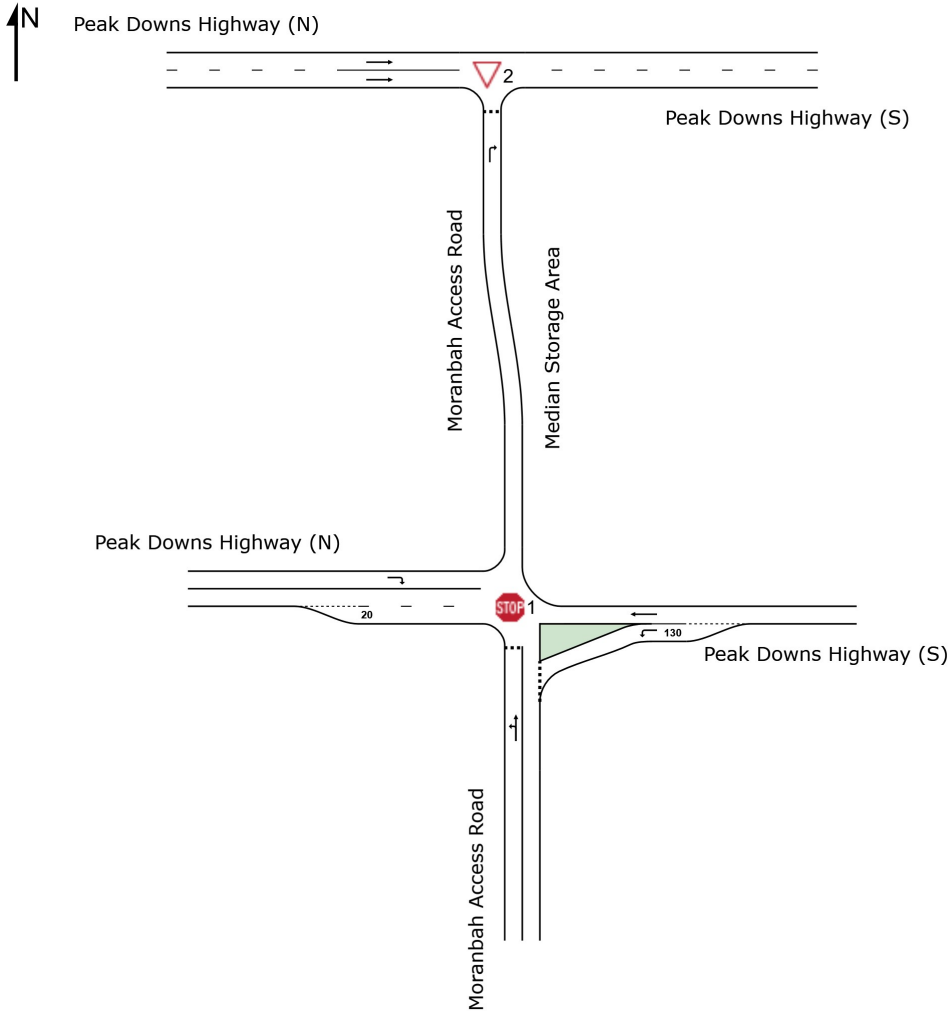

SITES IN NETWORK		
Site ID	CCG ID	Site Name
STOP 1	NA	2028PM - Base+Project
▽ 2	NA	2028PM -Base + Project

LANE SUMMARY

 Site: 1 [2028PM - Base+Project]

 Network: N101 [2028 PM - Base + Project Case]

Staged crossing Stage 1 (Minor Road) at three-way intersection with 5-lane major road. Major road turn lane is treated as a full-length lane.

Site Category: (None)

Stop (Two-Way)

Lane Use and Performance															
	Demand Flows		Arrival Flows		Cap.	Deg. Satn v/c	Lane Util. %	Average Delay sec	Level of Service	95% Back of Queue		Lane Config	Lane Length m	Cap. Adj. %	Prob. Block. %
	Total veh/h	HV %	Total veh/h	HV %						Veh	Dist m				
South: Moranbah Access Road															
Lane 1	507	10.4	507	10.4	1082	0.469	100	7.6	LOS A	3.1	23.8	Full	500	0.0	0.0
Approach	507	10.4	507	10.4		0.469		7.6	LOS A	3.1	23.8				
East: Peak Downs Highway (S)															
Lane 1	338	8.0	338	8.0	844	0.400	100	9.4	LOS A	2.3	17.2	Short	130	0.0	NA
Lane 2	625	3.0	62	53.0	1450	0.043	100	0.0	LOS A	0.0	0.0	Full	500	0.0	0.0
Approach	400	15.0	400	15.0		0.400		8.0	LOS A	2.3	17.2				
West: Peak Downs Highway (N)															
Lane 1	420	8.0	420	8.0	1614	0.260	100	5.9	LOS A	1.5	10.9	Full	500	0.0	0.0
Approach	420	8.0	420	8.0		0.260		5.9	NA	1.5	10.9				
Intersection	1327	11.0	1327	11.0		0.469		7.2	NA	3.1	23.8				

Site Level of Service (LOS) Method: Delay (SIDRA). Site LOS Method is specified in the Network Data dialog (Network tab).

Lane LOS values are based on average delay per lane.

Minor Road Approach LOS values are based on average delay for all lanes.

NA: Intersection LOS and Major Road Approach LOS values are Not Applicable for two-way sign control since the average delay is not a good LOS measure due to zero delays associated with major road lanes.

SIDRA Standard Delay Model is used. Control Delay includes Geometric Delay.

Gap-Acceptance Capacity: SIDRA Standard (Akçelik M3D).

HV (%) values are calculated for All Movement Classes of All Heavy Vehicle Model Designation.

LANE SUMMARY

Site: 2 [2028PM -Base + Project]

Network: N101 [2028 PM - Base + Project Case]

Staged crossing Stage 2 (Median) at three-way intersection with 5-lane major road.

Give-way behaviour assumed at Stage 2.

Site Category: (None)

Giveaway / Yield (Two-Way)

Lane Use and Performance															
	Demand Flows		Arrival Flows		Cap.	Deg. Satn v/c	Lane Util. %	Average Delay sec	Level of Service	95% Back of Queue		Lane Config	Lane Length m	Cap. Adj. %	Prob. Block. %
	Total veh/h	HV %	Total veh/h	HV %						Veh	Dist m				
South: Moranbah Access Road															
Lane 1	162	5.0	162	5.0	1337	0.121	100	0.2	LOS A	0.4	2.4	Full	7	0.0	0.0
Approach	162	5.0	162	5.0		0.121		0.2	LOS A	0.4	2.4				
West: Peak Downs Highway (N)															
Lane 1	3121.0	31	21.0	1716	0.018	0.018	100	0.0	LOS A	0.0	0.0	Full	500	0.0	0.0
Lane 2	3121.0	31	21.0	1716	0.018	0.018	100	0.0	LOS A	0.0	0.0	Full	500	0.0	0.0
Approach	6121.0	61	21.0			0.018		0.0	NA	0.0	0.0				
Intersection	223	9.4	223	9.4		0.121		0.1	NA	0.4	2.4				

Site Level of Service (LOS) Method: Delay (SIDRA). Site LOS Method is specified in the Network Data dialog (Network tab).

Lane LOS values are based on average delay per lane.

Minor Road Approach LOS values are based on average delay for all lanes.

NA: Intersection LOS and Major Road Approach LOS values are Not Applicable for two-way sign control since the average delay is not a good LOS measure due to zero delays associated with major road lanes.

SIDRA Standard Delay Model is used. Control Delay includes Geometric Delay.

Gap-Acceptance Capacity: SIDRA Standard (Akçelik M3D).

HV (%) values are calculated for All Movement Classes of All Heavy Vehicle Model Designation.

SIDRA INTERSECTION 8.0 | Copyright © 2000-2018 Akcelik and Associates Pty Ltd | sidrasolutions.com

Organisation: GTA CONSULTANTS | Processed: 27 November 2018 8:21:30 AM

Project: P:\Q12500-12599\Q125681 Olive Downs - RFI Response\Modelling\181120 - Intersection Modelling\Moranbah Access.sip8

RFI RESPONSE LETTER

Transport Engineering

ATTACHMENT E

Revised Pavement Impact Assessment Results – Peak Downs Highway and FDR

Project Generated Percentage Change in SAR - Gazetted

Section ID	2019	2020	2021	2022	2023	2024	2025	2026	2027	2028	2029	2030	2031	2032	2033	2034	2035	2036	2037	2038	2039	2040	2041	2042	2043	2044	2045	2046	2047	2048
150013	0.0%	0.0%	0.0%	0.0%	0.0%	0.0%	0.0%	0.0%	0.0%	0.0%	0.0%	0.0%	0.0%	0.0%	0.0%	0.0%	0.0%	0.0%	0.0%	0.0%	0.0%	0.0%	0.0%	0.0%	0.0%	0.0%	0.0%	0.0%	0.0%	0.0%
159613	0.0%	0.0%	0.0%	0.0%	0.0%	0.0%	0.0%	0.0%	0.0%	0.0%	0.0%	0.0%	0.0%	0.0%	0.0%	0.0%	0.0%	0.0%	0.0%	0.0%	0.0%	0.0%	0.0%	0.0%	0.0%	0.0%	0.0%	0.0%	0.0%	0.0%
150012	0.0%	0.4%	0.4%	0.4%	0.4%	0.4%	0.4%	0.6%	0.4%	0.6%	0.5%	0.5%	0.5%	0.7%	0.7%	0.7%	0.7%	0.7%	0.7%	0.7%	0.6%	0.6%	0.6%	0.6%	0.6%	0.6%	0.6%	1.3%	0.6%	0.6%
80147	22.7%	25.1%	24.8%	2.6%	2.6%	2.6%	2.5%	4.9%	2.4%	2.3%	1.8%	1.8%	1.8%	2.6%	2.5%	2.5%	2.5%	2.4%	2.4%	2.4%	2.3%	2.3%	2.3%	2.2%	2.2%	2.2%	2.2%	4.3%	2.1%	2.1%
80146	17.5%	19.1%	19.0%	1.7%	1.7%	1.7%	1.6%	2.9%	1.6%	1.4%	1.2%	1.2%	1.1%	1.7%	1.7%	1.7%	1.4%	1.6%	1.6%	1.6%	1.5%	1.5%	1.5%	1.5%	1.5%	1.5%	1.4%	2.8%	1.4%	1.4%
80197	21.0%	22.4%	20.4%	2.0%	2.0%	2.0%	1.9%	2.9%	1.8%	1.6%	1.7%	1.7%	1.7%	2.1%	2.0%	2.0%	2.0%	1.9%	1.9%	1.9%	1.9%	1.8%	1.8%	1.8%	1.7%	1.7%	1.7%	4.2%	1.7%	1.6%
82884	14.0%	15.1%	14.9%	1.3%	1.3%	1.3%	1.3%	2.7%	1.2%	1.0%	0.8%	0.8%	0.8%	1.4%	1.3%	1.3%	1.3%	1.3%	1.3%	1.2%	1.2%	1.2%	1.2%	1.2%	1.2%	1.2%	1.1%	1.9%	1.1%	1.1%
80009	17.0%	18.4%	18.1%	1.6%	1.6%	1.6%	1.5%	2.2%	1.5%	1.3%	1.3%	1.3%	1.3%	1.7%	1.6%	1.6%	1.6%	1.6%	1.5%	1.5%	1.5%	1.5%	1.5%	1.4%	1.4%	1.4%	1.4%	3.3%	1.3%	1.3%
83159	14.0%	15.1%	14.9%	1.3%	1.3%	1.3%	1.3%	2.6%	1.2%	1.0%	0.8%	0.8%	0.8%	1.4%	1.3%	1.3%	1.3%	1.3%	1.3%	1.2%	1.2%	1.2%	1.2%	1.2%	1.2%	1.2%	1.1%	1.9%	1.1%	1.1%
80020	11.8%	12.7%	12.8%	1.1%	1.1%	1.1%	1.1%	2.6%	1.0%	0.8%	0.6%	0.6%	0.6%	1.1%	1.1%	1.1%	1.1%	1.1%	1.1%	1.1%	1.0%	1.0%	1.0%	1.0%	1.0%	1.0%	1.0%	1.5%	0.9%	0.9%
82777	11.5%	12.5%	12.2%	1.1%	1.1%	1.1%	1.0%	2.5%	1.0%	0.8%	0.6%	0.6%	0.6%	1.1%	1.1%	1.1%	1.1%	1.1%	1.1%	1.0%	1.0%	1.0%	1.0%	1.0%	1.0%	0.9%	0.9%	1.5%	0.9%	0.9%
82778	6.1%	6.5%	6.4%	0.6%	0.6%	0.6%	0.5%	1.4%	0.5%	0.4%	0.3%	0.3%	0.3%	0.6%	0.6%	0.6%	0.6%	0.6%	0.5%	0.5%	0.5%	0.5%	0.5%	0.5%	0.5%	0.5%	0.5%	0.5%	0.5%	0.5%
82838	5.4%	5.9%	5.7%	0.5%	0.5%	0.5%	0.5%	1.3%	0.5%	0.4%	0.3%	0.3%	0.3%	0.5%	0.5%	0.5%	0.5%	0.5%	0.5%	0.5%	0.5%	0.5%	0.5%	0.5%	0.5%	0.4%	0.4%	0.7%	0.4%	0.4%
82839	7.8%	8.4%	8.2%	0.7%	0.7%	0.7%	0.7%	1.3%	0.7%	0.5%	0.5%	0.5%	0.5%	0.8%	0.7%	0.7%	0.7%	0.7%	0.7%	0.7%	0.7%	0.7%	0.7%	0.7%	0.6%	0.6%	0.6%	1.2%	0.6%	0.6%
150009	0.0%	0.0%	0.0%	0.0%	0.0%	0.0%	0.0%	0.0%	0.0%	0.0%	0.0%	0.0%	0.0%	0.0%	0.0%	0.0%	0.0%	0.0%	0.0%	0.0%	0.0%	0.0%	0.0%	0.0%	0.0%	0.0%	0.0%	0.0%	0.0%	0.0%
80191	0.0%	0.0%	0.0%	0.0%	0.0%	0.0%	0.0%	0.0%	0.0%	0.0%	0.0%	0.0%	0.0%	0.0%	0.0%	0.0%	0.0%	0.0%	0.0%	0.0%	0.0%	0.0%	0.0%	0.0%	0.0%	0.0%	0.0%	0.0%	0.0%	0.0%
80025	0.0%	0.0%	0.0%	0.0%	0.0%	0.0%	0.0%	0.0%	42.7%	3.9%	3.7%	3.7%	3.6%	4.7%	4.6%	4.4%	4.5%	4.5%	4.4%	4.4%	4.3%	4.3%	4.2%	4.1%	4.1%	4.0%	3.9%	3.9%	3.9%	3.8%

Project Generated Percentage Change in SAR - Against

Section ID	2019	2020	2021	2022	2023	2024	2025	2026	2027	2028	2029	2030	2031	2032	2033	2034	2035	2036	2037	2038	2039	2040	2041	2042	2043	2044	2045	2046	2047	2048
150013	0.0%	0.0%	0.0%	0.0%	0.0%	0.0%	0.0%	0.0%	0.0%	0.0%	0.0%	0.0%	0.0%	0.0%	0.0%	0.0%	0.0%	0.0%	0.0%	0.0%	0.0%	0.0%	0.0%	0.0%	0.0%	0.0%	0.0%	0.0%	0.0%	0.0%
159613	0.0%	0.0%	0.0%	0.0%	0.0%	0.0%	0.0%	0.0%	0.0%	0.0%	0.0%	0.0%	0.0%	0.0%	0.0%	0.0%	0.0%	0.0%	0.0%	0.0%	0.0%	0.0%	0.0%	0.0%	0.0%	0.0%	0.0%	0.0%	0.0%	0.0%
150012	0.0%	0.3%	0.3%	0.3%	0.3%	0.3%	0.3%	0.7%	0.3%	0.4%	0.3%	0.3%	0.3%	0.5%	0.5%	0.5%	0.5%	0.5%	0.5%	0.4%	0.4%	0.4%	0.4%	0.1%	0.4%	0.4%	0.4%	0.4%	0.4%	0.4%
80147	14.6%	14.0%	14.0%	1.7%	1.7%	1.6%	1.6%	3.8%	1.5%	1.2%	0.9%	0.9%	0.9%	1.6%	1.6%	1.6%	1.6%	1.5%	1.5%	1.5%	1.5%	1.5%	1.5%	0.3%	1.4%	1.4%	1.4%	1.4%	1.3%	1.3%
80146	20.7%	22.5%	22.4%	2.0%	2.0%	2.0%	1.9%	2.9%	1.9%	1.7%	1.6%	1.6%	1.6%	2.0%	2.0%	2.0%	1.9%	1.9%	1.9%	1.9%	1.8%	1.8%	1.8%	0.3%	1.7%	1.7%	1.7%	1.7%	1.7%	1.6%
80197	16.3%	17.5%	17.3%	1.6%	1.5%	1.5%	1.5%	2.7%	1.4%	1.3%	1.1%	1.1%	1.1%	1.6%	1.6%	1.5%	1.5%	1.5%	1.5%	1.4%	1.4%	1.4%	1.4%	0.2%	1.4%	1.3%	1.3%	1.3%	1.3%	1.3%
82884	10.5%	11.3%	11.2%	1.0%	1.0%	1.0%	1.0%	1.5%	0.9%	0.7%	0.8%	0.7%	0.7%	1.0%	1.0%	1.0%	1.0%	1.0%	0.9%	0.9%	0.9%	0.9%	0.2%	0.9%	0.9%	0.9%	0.8%	0.8%	0.8%	0.8%
80009	14.4%	15.6%	15.4%	1.4%	1.4%	1.3%	1.3%	2.3%	1.3%	1.1%	1.0%	1.0%	1.0%	1.4%	1.4%	1.4%	1.3%	1.3%	1.3%	1.3%	1.3%	1.3%	1.2%	0.2%	1.2%	1.2%	1.2%	1.2%	1.2%	1.1%
83159	9.0%	9.8%	9.6%	0.9%	0.9%	0.8%	0.8%	1.2%	0.8%	0.7%	0.5%	0.5%	0.5%	0.9%	0.9%	0.9%	0.8%	0.8%	0.8%	0.8%	0.8%	0.8%	0.1%	0.8%	0.7%	0.7%	0.7%	0.7%	0.7%	0.7%
80020	13.3%	14.4%	14.1%	1.3%	1.3%	1.2%	1.2%	2.5%	1.2%	1.0%	0.8%	0.8%	0.8%	1.3%	1.3%	1.3%	1.2%	1.2%	1.2%	1.2%	1.2%	1.2%	1.1%	0.2%	1.1%	1.1%	1.1%	1.1%	1.1%	1.0%
82777	11.3%	12.2%	12.0%	1.1%	1.1%	1.0%	1.0%	2.4%	1.0%	0.8%	0.6%	0.6%	0.6%	1.1%	1.1%	1.1%	1.1%	1.0%	1.0%	1.0%	1.0%	1.0%	0.1%	0.9%	0.9%	0.9%	0.9%	0.9%	0.9%	0.9%
82778	10.9%	11.8%	11.6%	1.0%	1.0%	1.0%	1.0%	1.9%	1.0%	0.9%	0.7%	0.7%	0.7%	1.1%	1.0%	1.0%	1.0%	1.0%	1.0%	1.0%	1.0%	0.9%	0.9%	0.1%	0.9%	0.9%	0.9%	0.9%	0.9%	0.9%
82838	9.0%	9.8%	9.6%	0.9%	0.9%	0.8%	0.8%	1.3%	0.8%	0.7%	0.7%	0.7%	0.6%	0.9%	0.9%	0.9%	0.8%	0.8%	0.8%	0.8%	0.8%	0.8%	0.1%	0.8%	0.7%	0.7%	0.7%	0.7%	0.7%	0.7%
82839	11.4%	12.3%	12.0%	1.1%	1.1%	1.1%	1.0%	2.4%	1.0%	0.9%	0.7%	0.7%	0.7%	1.1%	1.1%	1.1%	1.1%	1.0%	1.0%	1.0%	1.0%	1.0%	0.1%	0.9%	0.9%	0.9%	0.9%	0.9%	0.9%	0.9%
150009	0.0%	0.0%	0.0%	0.0%	0.0%	0.0%	0.0%	0.0%	0.0%	0.0%	0.0%	0.0%	0.0%	0.0%	0.0%	0.0%	0.0%	0.0%	0.0%	0.0%	0.0%	0.0%	0.0%	0.0%	0.0%	0.0%	0.0%	0.0%	0.0%	0.0%
80191	0.0%	0.0%	0.0%	0.0%	0.0%	0.0%	0.0%	0.0%	0.0%	0.0%	0.0%	0.0%	0.0%	0.0%	0.0%	0.0%	0.0%	0.0%	0.0%	0.0%	0.0%	0.0%	0.0%	0.0%	0.0%	0.0%	0.0%	0.0%	0.0%	0.0%
80025	0.0%	0.0%	0.0%	0.0%	0.0%	0.0%	0.0%	0.0%	39.4%	3.6%	3.4%	3.4%	3.3%	4.4%	4.3%	4.2%	4.2%	4.2%	4.1%	4.0%	4.0%	3.9%	3.9%	0.6%	3.8%	3.7%	3.6%	3.6%	3.6%	3.6%

RFI RESPONSE LETTER

Transport Engineering

ATTACHMENT F

Additional Pavement Impact Assessment Results – Moranbah Access Road

Project Generated Percentage Change in SAR

Northbound	2019	2020	2021	2022	2023	2024	2025	2026	2027	2028	2029	2030	2031	2032	2033	2034	2035	2036	2037	2038	2039	2040	2041	2042	2043	2044	2045	2046	2047	2048	
AM	8%	16%	16%	16%	16%	16%	16%	16%	19%	19%	18%	18%	18%	18%	18%	18%	17%	17%	17%	17%	16%	16%	16%	16%	16%	15%	15%	15%	15%	15%	
PM	9%	18%	18%	18%	18%	18%	18%	18%	21%	21%	21%	21%	20%	20%	20%	20%	18%	18%	18%	18%	18%	18%	18%	18%	18%	17%	17%	17%	17%	17%	
Southbound	2019	2020	2021	2022	2023	2024	2025	2026	2027	2028	2029	2030	2031	2032	2033	2034	2035	2036	2037	2038	2039	2040	2041	2042	2043	2044	2045	2046	2047	2048	
AM	6%	13%	13%	13%	13%	13%	13%	13%	16%	15%	15%	15%	14%	14%	14%	14%	14%	14%	13%	13%	13%	13%	13%	13%	13%	12%	12%	12%	12%	12%	
PM	10%	30%	21%	21%	21%	21%	21%	21%	24%	26%	26%	25%	24%	24%	24%	24%	23%	23%	23%	23%	23%	23%	23%	23%	23%	23%	20%	20%	20%	20%	20%